

INSTALLATION MANUAL

R-410A ZT SERIES W/SMART EQUIPMENT™

15 - 23 Ton

60 Hertz



Table of contents

General	2	Outputs	28
Installation	5	Operation	28
Preceding installation	5	Smart Equipment™ economizer board	29
Limitations	5	Adjusting the power exhaust damper setpoint for the optional	
Location	7	BAS-ready economizer	33
Clearances	7	Optional variable air volume	33
Rigging and handling	7	Hot gas bypass	34
Ductwork	13	Air balance	40
Fixed outdoor air intake damper	13	Checking air quantity	40
Condensate drain	14	Sequence of operation	42
Compressors	14	Cooling sequence of operation	42
Filters	15	Cooling operation errors	43
Power and control wiring	15	Reheat sequence of operation	44
Field-installed electric heat accessories	25	Electric heating sequence of operations	44
Optional gas heat	25	Electric heat operation errors	45
Options and accessories	27	Gas heating sequence of operations	46
Economizer sequences	27	Gas heating operation errors	46
Dry bulb changeover	28	Cooling start-up	48
Single enthalpy changeover	28	Gas heat start-up	48
Dual enthalpy changeover	28	Checking gas heat input	49
Auto	28	Charging the unit	51
Free cooling operation	28	Smart Equipment™ unit control board	55
Power exhaust	28	Four-stage board	61
Setpoints	28	Start-up sheet	65
Inputs	28		

List of tables

1 Component location table	6	20 ZT180-210 3 stage dehumidification sequence in normal and alternate mode	44
2 ZT180-276 unit limitations	7	21 ZT240-276 4 stage dehumidification sequence in normal and alternate mode	44
3 ZT180-276 unit accessory weights	9	22 Limit control setting	45
4 Supply fan VFD weights, in lbs.	9	23 Electric heat anticipator setpoint	45
5 Utilities entry	10	24 Gas heat limit control setting	47
6 ZT180-276 unit clearances	12	25 Gas heat anticipator setpoints	48
7 Control wire sizes	17	26 Gas rate cubic feet per hour	49
8 Electrical data	18	27 ZT180 charging table - system 1	51
9 ZT180-276 physical data	23	28 ZT180 charging table - system 2	51
10 Electric heat minimum supply air	25	29 ZT210 charging table - system 1	52
11 Gas application data	25	30 ZT210 charging table - system 2	52
12 Gas pipe sizing - capacity of pipe	25	31 ZT240 charging table - system 1	53
13 Gas heat minimum supply air	26	32 ZT240 charging table - system 2	53
14 Altitude/temperature correction factors	35	33 ZT276 charging table - system 1	54
15 Air flow performance - side duct application	37	34 ZT276 charging table - system 2	54
16 Air flow performance - bottom duct application	38	35 Cable for FC buses and SA buses in order of preference	64
17 RPM selection	39		
18 Indoor blower specifications	40		
19 Power exhaust specifications	40		

List of figures

1 ZT180-276 component location	6	15 Vent and combustion air hood	27
2 Unit 4 point load weight	8	16 SE-ECO1001-0 economizer controller	29
3 Unit 6 point load weight	8	17 Belt adjustment	34
4 Center of gravity	8	18 Altitude/temperature correction factors	35
5 ZT180-276 unit dimensions front view	10	19 Pressure drop across a dry indoor coil vs. supply air CFM for all unit tonnages	40
6 ZT180-276 unit dimensions rear view	11	20 Gas valve piping	46
7 ZT180-276 unit dimensions rain hood	12	21 Burner compartment - gas valve and controls	47
8 ZT180-276 roof curb	13	22 Pilot flame adjustment	50
9 Fixed outdoor air damper	14	23 Typical flame	50
10 Condensate drain	14	24 Typical gas valve	50
11 Field wiring disconnect - cooling unit with/without electric heat	16	25 Smart Equipment™ unit control board	55
12 Typical field wiring 24 volt thermostat	17	26 Four-stage board	61
13 External supply connection external shut-off	25		
14 Bottom supply connection external shut-off	25		

General

YORK® Model ZT units are single package air conditioners equipped with electric heaters (field-installed accessory only) or single package gas-fired central heating furnaces with a cooling unit. Both types of unit are designed for outdoor installation on a rooftop or slab.

The units are completely assembled on rigid, permanently attached base rails. All piping, refrigerant charge, and electrical wiring is factory installed and tested. The units require the following at the point of installation.

- Electric power
- Gas connection
- Duct connections
- The installation of a combustion air inlet hood
- The installation of flue gas outlet hoods
- The installation of a fixed outdoor air intake damper. Only for units without economizer or motorized damper

The electric heater accessories have nickel-chrome elements and use a single point power connection.

The gas-fired heaters have aluminized-steel or optional stainless steel, tubular heat exchangers with spark ignition with proven pilot. All gas heaters are shipped from the factory equipped for natural gas use. The gas heaters can be field converted to L.P./Propane with kit number 1NP0418. See Gas Heat Application Data Table.

Safety considerations

 This is a safety alert symbol. When you see this symbol on labels or in manuals, be alert to the potential for personal injury.

Understand and pay particular attention the signal words **DANGER**, **WARNING** or **CAUTION**.

DANGER indicates an **imminently** hazardous situation, which, if not avoided, **will result in death or serious injury**.

WARNING indicates a **potentially** hazardous situation, which, if not avoided, **could result in death or serious injury**.

CAUTION indicates a potentially hazardous situation, which, if not avoided **may result in minor or moderate injury**. It is also used to alert against unsafe practices and hazards involving only property damage.

WARNING

Improper installation may create a condition where the operation of the product could cause personal injury or property damage. Improper installation, adjustment, alteration, service or maintenance can cause injury or property damage. Refer to this manual for assistance or for additional information, consult a qualified contractor, installer or service agency.

CAUTION

This product must be installed in strict compliance with the installation instructions and any applicable local, state and national codes including, but not limited to building, electrical, and mechanical codes.

WARNING

Before you perform service or maintenance operations on the unit, turn off the main power switch to the unit. Electrical shock could cause personal injury. Improper installation, adjustment, alteration, service or maintenance can cause injury or property damage. Refer to this manual. For assistance or additional information consult a qualified installer, service agency or the gas supplier.

CAUTION

This system uses R-410A refrigerant which operates at higher pressures than R-22. No other refrigerant may be used in this system. Gage sets, hoses, refrigerant containers and recovery systems must be designed to handle R-410A. If you are unsure, consult the equipment manufacturer. Failure to use R-410A compatible servicing equipment may result in property damage or injury.

WARNING

If the information in this manual is not followed exactly, a fire or explosion may result causing property damage, personal injury or loss of life.

Do not store or use gasoline or other flammable vapors and liquids in the vicinity of this or any other appliance.

What to do if you smell gas

- Do not try to light any appliance.
- Do not touch any electrical switch.
- Do not use any phone in your building.
- Immediately call your gas supplier from a neighbor's phone. Follow the gas supplier's instructions.
- If you cannot reach your gas supplier, call the fire department.

Installation and service must be performed by a qualified installer, service agency, or the gas supplier.

Due to system pressure, moving parts, and electrical components, the installation and servicing of air conditioning equipment can be hazardous. Only qualified, trained service personnel must install, repair, or service this equipment.

Untrained personnel can perform basic maintenance functions of cleaning coils and filters, and replacing filters.

Observe all the precautions in the literature, labels, and tags that accompany the equipment whenever you work on air conditioning equipment. Be sure to follow all other applicable safety precautions and codes including ANSI Z223.1 or CSA-B149.1- latest edition.

Wear safety glasses and work gloves. Use quenching cloth and have a fire extinguisher available during brazing operations.

Inspection

As soon as you receive a unit, you must inspect it for possible damage during transit. If damage is evident, note the extent of the damage on the carrier's freight bill. You must make a separate request for inspection by the carrier's agent in writing.

CAUTION

This product must be installed in strict compliance with the enclosed installation instructions and any applicable local, state and national codes including, but not limited to, building, electrical, and mechanical codes.

The furnace and its individual shut-off valve must be disconnected from the gas supply piping system during any pressure testing at pressures in excess of 1/2 PSIG.

Pressures greater than 1/2 PSIG will cause gas valve damage resulting in a hazardous condition. If it is subjected to a pressure greater than 1/2 PSIG, the gas valve must be replaced.

The furnace must be isolated from the gas supply piping system by closing its individual manual shut-off valve during any pressure testing of the gas supply piping system at test pressures equal to or less than 1/2 PSIG.

Reference

Additional information is available in the following reference forms:

- Technical Guide - ZT180-276, 5566232
- General Installation - ZT180-276, 5553127

- Electric Heat Accessory Installation - 5128261
- Smart Equipment™ Control Quick Start Guide - 1136326
- Scan the QR code on the unit data tag to access the on-line start-up form for this unit.

Renewal parts

Contact your local York® parts distribution center for authorized replacement parts.

Approvals

The design is certified by CSA as follows:

- For use as a cooling only unit, cooling unit with supplemental electric heat, or a forced air furnace.
- For outdoor installation only.
- For installation on combustible material.
- For use with natural gas. The unit can be converted to LP with a kit.

CAUTION

This product must be installed in strict compliance with the enclosed installation instructions and any applicable local, state, and national codes including, but not limited to, building, electrical, and mechanical codes.

WARNING

Improper installation may create a condition where the operation of the product could cause personal injury or property damage.

CAUTION

This system uses R-410A refrigerant which operates at higher pressures than R-22. No other refrigerant may be used in this system.

Nomenclature

15-23 Ton York® Model Number Nomenclature

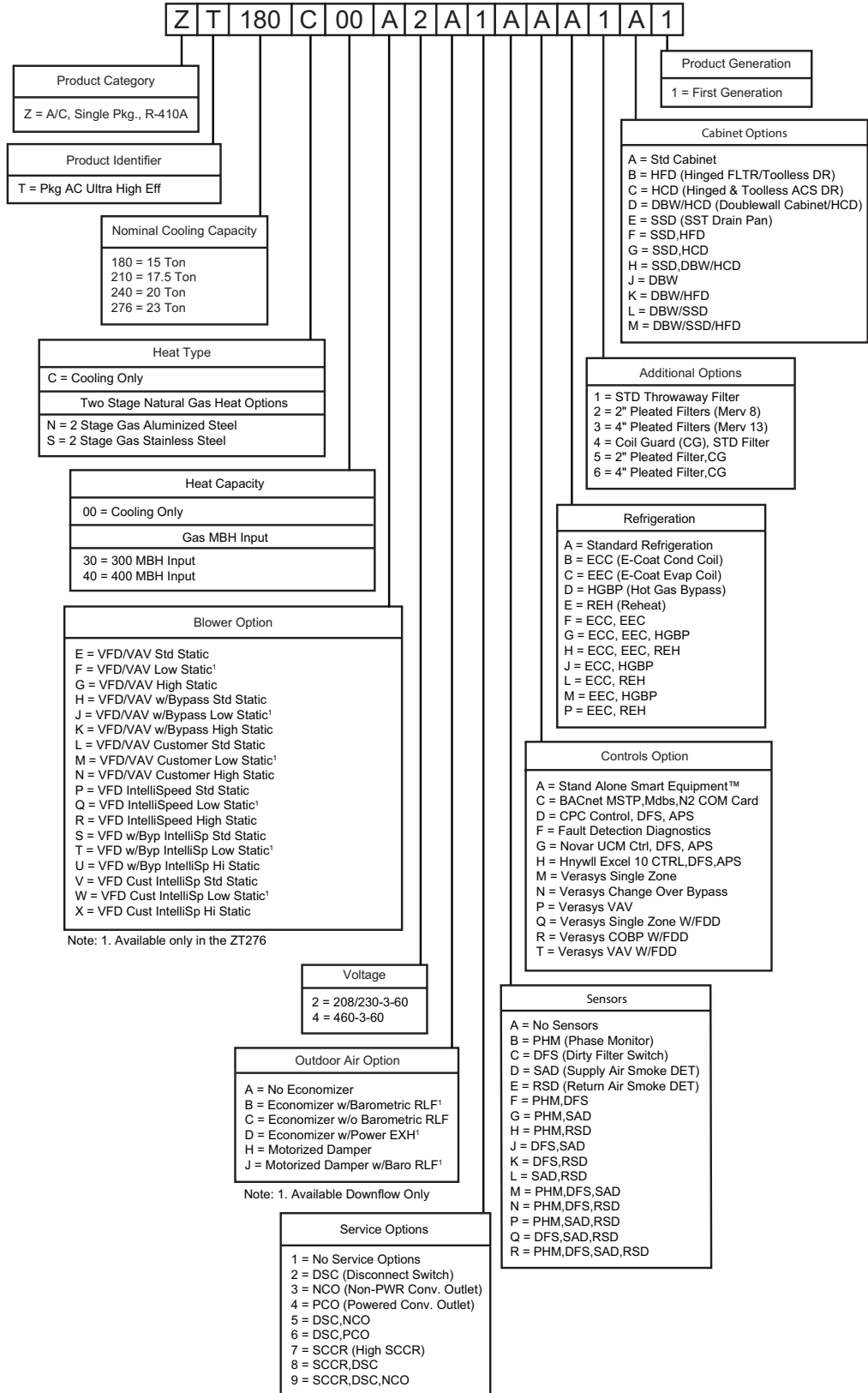

Installation

Installation safety information

Read the following instructions before you install this appliance. This is an outdoor combination heating and cooling unit. The installer must assure that these instructions are made available to the consumer. The installer must instruct the consumer to retain the instructions for future reference.

- Refer to the unit rating plate for the approved type of gas for this product.
- Install this unit only in a location and position as specified on page 7 of these instructions.
- Never test for gas leaks with an open flame. Use commercially available soap solution made specifically for the detection of leaks when you check all connections. See pages 5, 26, 27 and 48 of these instructions.
- Always install the furnace to operate within the furnace's intended temperature-rise range with the duct system and within the allowable external static pressure range. This information is specified on the unit name/rating plate and specified on page 49 of these instructions.
- This equipment is not to be used for the temporary heating of buildings or structures under construction.

WARNING

Fire or explosion hazard

Failure to follow the safety warning exactly could result in serious injury, death or property damage.

Never test for gas leaks with an open flame. Use a commercially available soap solution made specifically for the detection of leaks to check all connections. A fire or explosion may result causing property damage, personal injury, or loss of life.

Preceding installation

If a factory option convenience outlet is installed, you must install the weatherproof outlet cover in the field. The cover is located in the unit control box.

Installing the outlet cover

1. Remove the shipping label that covers the convenience outlet.
2. Follow the instructions on the back of the weatherproof cover box.
3. Attach the cover to the unit with the four screws provided.

CAUTION

208/230-3-60 and 380/415-3-50 units with factory-installed powered convenience outlet option are wired for 230v and 415v power supply respectively. Change the tap on the transformer for 208-3-60 or 380-3-50 operation. See the unit wiring diagram.

Limitations

The units must be installed in accordance with the following:

In U.S.A.:

1. National Electrical Code, ANSI/NFPA No. 70 - latest edition
2. National Fuel Gas Code, ANSI Z223.1 - latest edition
3. Gas-Fired Central Furnace Standard, ANSI Z21.47a. - latest edition
4. Local building codes
5. Local gas utility requirements

In Canada:

1. Canadian Electrical Code, CSA C22.1
2. Installation Codes, CSA - B149.1
3. Local plumbing and waste water codes
4. Other applicable local codes.

Refer to unit application data found in this document.

After the installation is complete, you must adjust gas fired units to obtain a temperature rise within the range specified on the unit rating plate.

If components are added to a unit to meet local codes, they are installed at the dealer's and/or customer's expense.

The size of the unit for the proposed installation must be based on a heat loss/heat gain calculation made according to the methods of the Air Conditioning Contractors of America (ACCA).

Do not use this furnace for temporary heating of buildings or structures under construction.

CAUTION

The Smart Equipment™ control board used in this product will effectively operate the cooling system down to 0°F when this product is applied in a comfort cooling application for people. An economizer is typically included in this type of application. When you apply this product for process cooling applications (such as computer rooms or switchgear), please call the applications department for Ducted Systems @ 1-877-874-SERV for guidance. Additional accessories may be needed for stable operation at temperatures below 30°F.

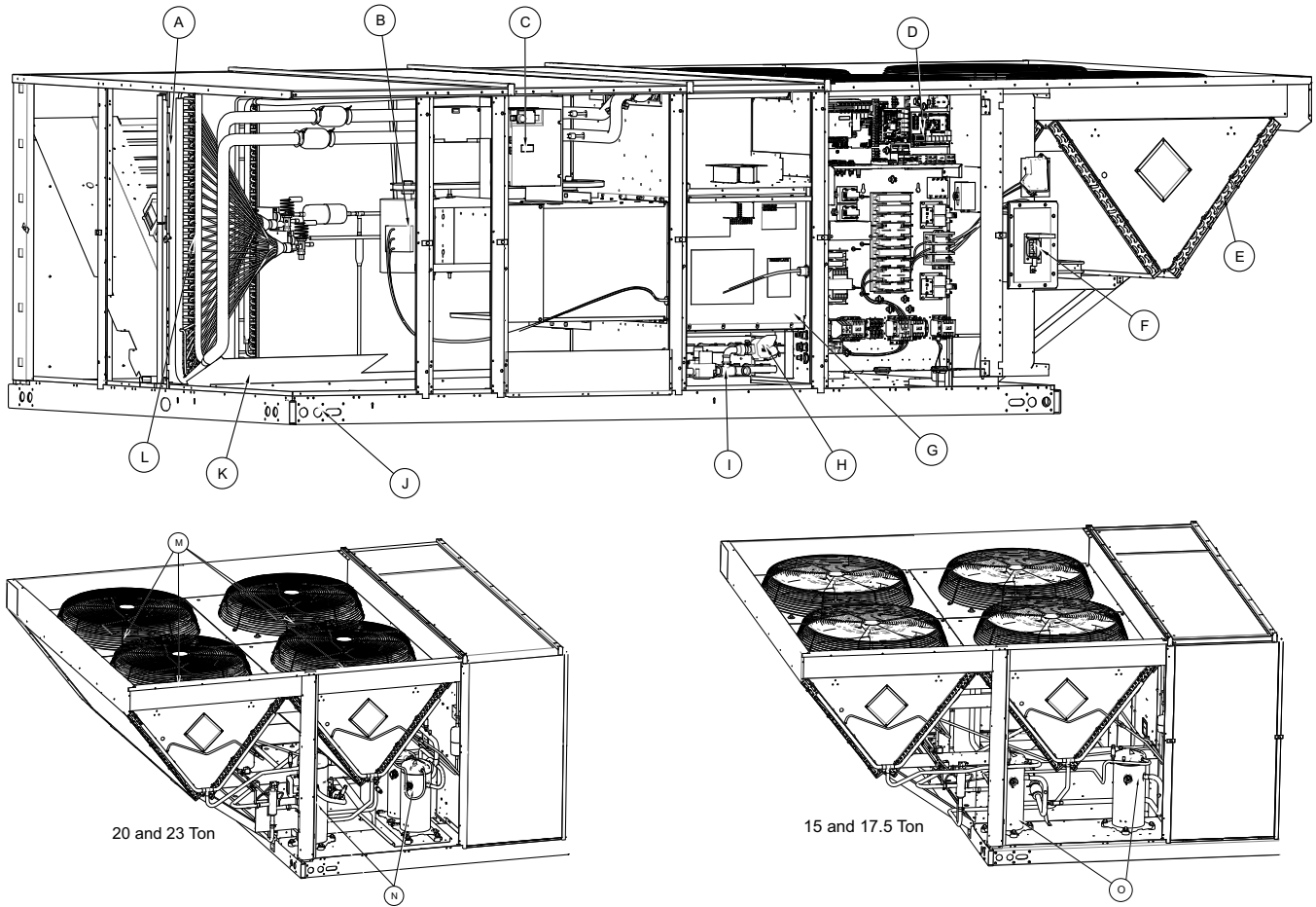

Figure 1: ZT180-276 component location

Table 1: Component location table

Item	Description
A	Filter access, 2-inch or 4-inch filter options
B	Premium efficiency belt-drive blower motor
C	Variable frequency drive
D	Smart Equipment™ supply fan controls with IntelliSpeed™
E	Copper tube/aluminum fin condenser coils
F	Disconnect location, optional disconnection switch
G	Intelligent control board for safe and efficient operation
H	Two stage gas heating to maintain a warm, comfortable temperature
I	20-gauge aluminized steel tubular heat exchanger for long life. Stainless steel option
J	Full perimeter base rails with holes for overhead rigging
K	Drain pan with 1-inch NPT connection
L	High efficiency sine wave fin evaporator coil
M	ECM outdoor fan motor
N	20 and 23 ton units: two speed compressor on circuit 2 and uneven tandem compressors on circuit 1
O	15 and 17.5 ton units: two speed compressors on both circuit 2 and circuit 1

Table 2: ZT180-276 unit limitations

Size (tons)	Unit voltage	Unit limitations		
		Applied voltage		Outdoor DB temp
		Minimum	Maximum	Maximum (°F)
180 (15)	208/230-3-60	187	252	125
	460-3-60	432	504	125
210 (17.5)	208/230-3-60	187	252	125
	460-3-60	432	504	125
240 (20)	208/230-3-60	187	252	125
	460-3-60	432	504	125
276 (23)	208/230-3-60	187	252	125
	460-3-60	432	504	125

▲ WARNING

Excessive exposure of the furnace to contaminated combustion air may result in equipment damage or personal injury. Typical contaminants include the following items:

- Permanent wave solution
- Chlorinated waxes and cleaners
- Chlorine based swimming pool chemicals
- Water softening chemicals
- Carbon tetrachloride
- Halogen type refrigerants
- Cleaning solvents (for example, perchloroethylene)
- Printing inks
- Paint removers
- Varnishes
- Hydrochloric acid
- Cements and glues
- Anti static fabric softeners for clothes dryers
- Masonry acid washing materials

Location

Use the following guidelines to select a suitable location for these units:

- The unit is designed for *outdoor installation only*.
- Condenser coils must have an unlimited supply of air. Where a choice of location is possible, position the unit on either the north or east side of the building.
- Suitable for mounting on roof curb.
- For ground level installation, use a level concrete slab with a minimum thickness of 4 inches. The length and width must be at least 6 inches greater than the unit base rails. Do not tie the slab to the building foundation.
- Roof structures must be able to support the weight of the unit and its options and accessories. The unit must be installed on a solid, level roof curb or appropriate angle iron frame.

- Maintain level tolerance to 1/2 inch across the entire width and length of the unit.

Clearances

All units require particular clearances for proper operation and service. The installer must make provisions for adequate combustion and ventilation air in accordance with section 5.3 of Air for Combustion and Ventilation of the National Fuel Gas Code, ANSI Z223.1 – latest edition (in U.S.A.), or Sections 7.2, 7.3, or 7.4 of Gas Installation Codes, CSA-B149.1 (in Canada) - latest edition, and/or applicable provisions of the local building codes. See Table 6 for the clearances required for combustible construction, servicing, and proper unit operation.

▲ WARNING

Do not permit overhanging structures or shrubs to obstruct the condenser air discharge outlet, combustion air inlet, or vent outlets.

Rigging and handling

Exercise care when you move the unit. Do not remove any packaging until the unit is near the place of installation. To rig the unit, attach chain or cable slings to the lifting holes provided in the base rails. You must use spreader bars across the top of the unit. The spreader bars must have a length that exceeds the largest dimension across the unit.

▲ CAUTION

If a unit is installed on a roof curb other than a York[®] roof curb, you must apply gasketing to all surfaces that come in contact with the unit underside.

▲ CAUTION

Before lifting the unit, make sure that the unit weight is distributed equally on the rigging cables so that it lifts evenly.

Units may be moved or lifted with a forklift from the side only, providing an accessory skid is used.

THE LENGTH OF THE FORKS MUST BE A MINIMUM OF 90 INCHES.

⚠ CAUTION

All panels must be secured in place when the unit is lifted.

Protect the condenser coils from rigging cable damage with plywood or other suitable material.

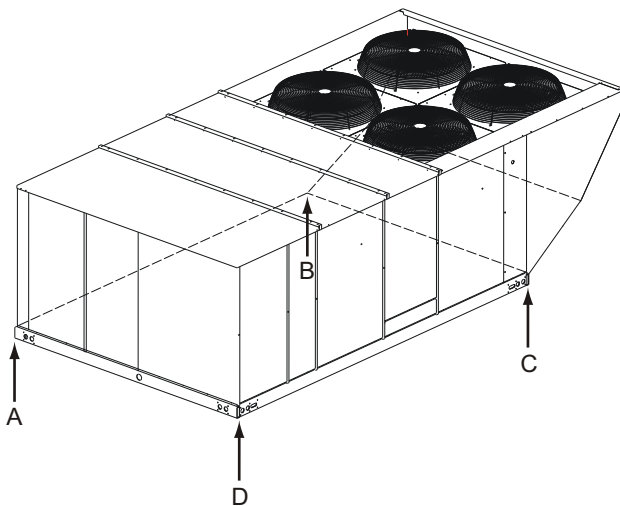

Figure 2: Unit 4 point load weight

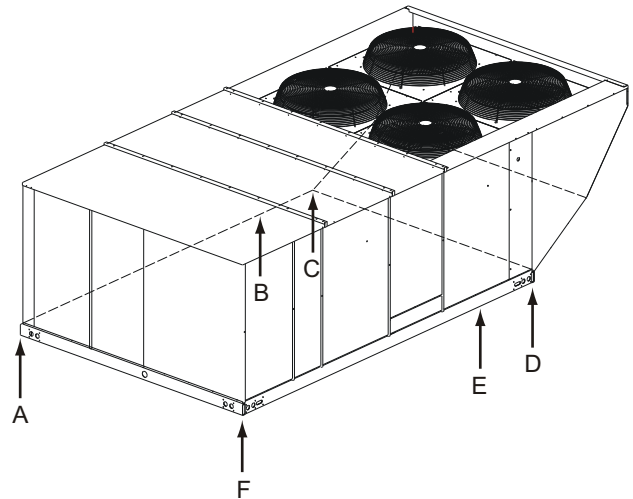

Figure 3: Unit 6 point load weight

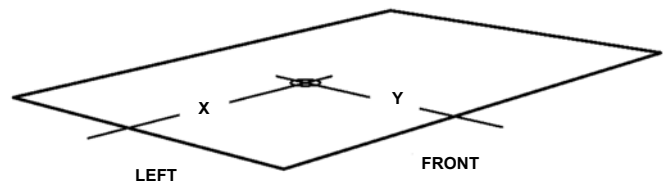

Figure 4: Center of gravity

ZT180-276 unit weights

Size (tons)	Model	Weight (lbs.)		Center of gravity		4 point load location (lbs.)				6 point load location (lbs.)					
		Shipping	Operating	X	Y	A	B	C	D	A	B	C	D	E	F
180 (15)	ZT	2605	2600	85.5	43.4	457	770	862	512	281	385	561	628	431	314
210 (17.5)	ZT	2735	2730	85.2	43.6	485	809	898	538	298	407	589	653	452	331
240 (20)	ZT	2860	2855	86.5	45.5	516	896	916	527	315	440	657	671	450	322
276 (23)	ZT	2930	2925	85	43.75	523	868	957	577	322	438	631	695	483	355

ZT180-276 Reheat unit weights

Size (tons)	Model	Weight (lbs.)		Center of gravity		4 point load location (lbs.)				6 point load location (lbs.)					
		Shipping	Operating	X	Y	A	B	C	D	A	B	C	D	E	F
180 (15)	ZT	2675	2670	84.8	43	471	777	885	537	290	394	564	642	449	331
210 (17.5)	ZT	2825	2820	84.9	42.9	496	819	938	567	305	415	595	681	474	349
240 (20)	ZT	2990	2985	86	44.5	532	911	973	568	326	452	666	711	482	348
276 (23)	ZT	3040	3035	85.4	43.4	534	897	1005	598	328	450	653	732	504	368

Table 3: ZT180-276 unit accessory weights

Unit accessory	Weight (lbs.)	
	Shipping	Operating
Economizer	165	160
Power exhaust	90	85
Electric heat ¹	40	40
Gas heat ²	240	240
Double wall	260	260
Motorized damper	150	150
Barometric damper	50	45
Econ./motorized damper rain hood	60	55
Econ./power exhaust rain hood	95	90
Wood skid	220	220
Roof curb	190	185
Hot gas bypass	10	10
Supply fan VFD	See Table 4	

1. The weight given is for the maximum heater size available (72kW).
2. The weight given is for the maximum number of tube heat exchangers available (8 tubes).

Table 4: Supply fan VFD weights, in lbs.

Supply fan motor	230V	460V
Without manual bypass		
5.0 hp	25	25
7.5 hp	30	30
10.0 hp	30	30
15.0 hp	30	30
With manual bypass		
5.0 hp	30	30
7.5 hp	35	35
10.0 hp	35	35
15.0 hp	40	35

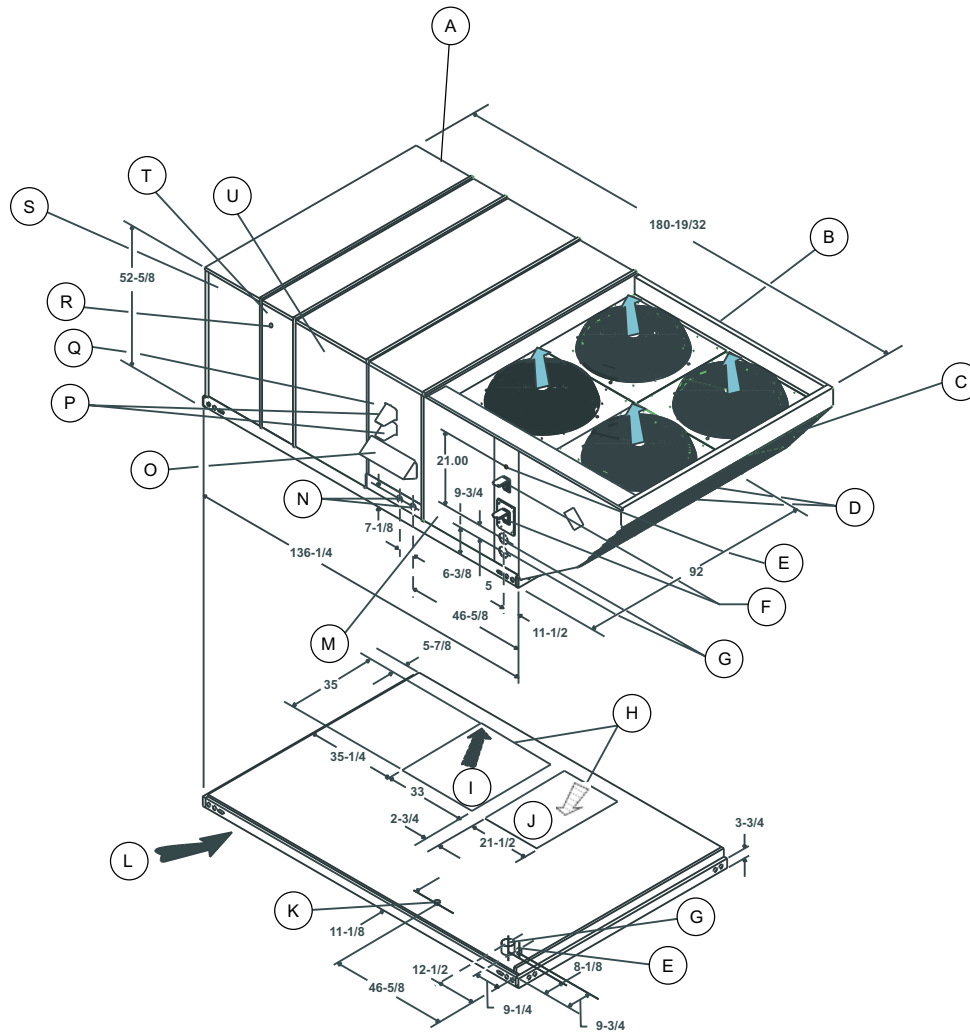

Item	Description
A	Economizer/motorized damper fixed outdoor intake air and power exhaust rain hoods. See detail Y
B	Compressor access
C	Coil guard kit
D	Condenser coils
E	Control wiring entry (A)
F	Disconnect switch location
G	Power wiring entry (B)
H	Bottom supply and return air openings ¹
I	Return air
J	Supply air
K	Gas supply entry (D)

Item	Description
L	Unit base rails: shown separately to show the bottom duct openings and power and gas piping location
M	Control box access location
N	Gas supply entry (C)
O	Combustion air inlet hood
P	Vent air outlet hoods
Q	Gas or electric heat access
R	Dot plug for pressure drop reading
S	Blower compartment access (auxiliary)
T	Blower motor access and location of optional VFD bypass
U	Blower access and location of optional VFD

1. For curb mounted units, refer to the curb hanger dimensions of the curb for the size of the supply and return air duct connections.

Figure 5: ZT180-276 unit dimensions front view

Table 5: Utilities entry

Hole	Opening size diameter	Used for	
A	1-1/8 in. KO	Control wiring	Front
	3/4 in. NPS (fem.)		Bottom
B	3-5/8 in. KO	Power wiring	Front
	3 in. NPS (fem.)		Bottom
C	2-3/8 in. KO	Gas piping (front) ¹	
D	1-11/16 in. hole	Gas piping (bottom) ^{1,2}	

1. One-inch gas piping NPT required.
2. Opening in the bottom to the unit can be located by the slice in the insulation.

Note: You must seal all entry holes to prevent rain water entry into the building.

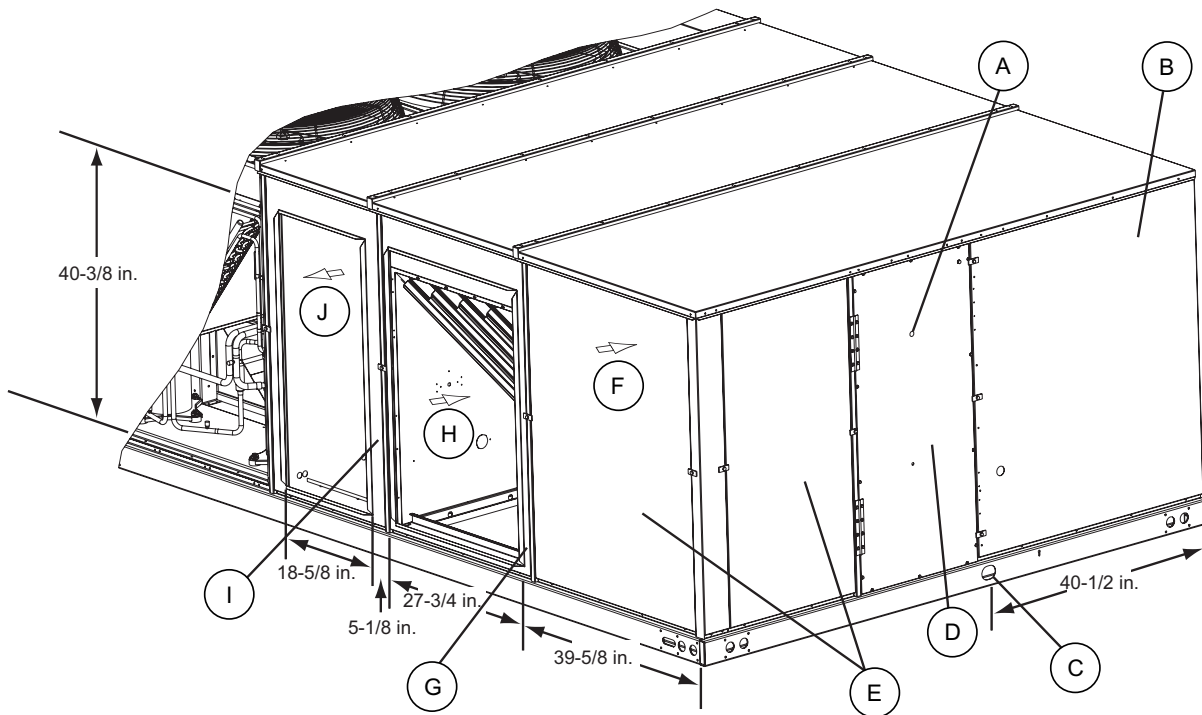

Item	Description
A	Dot plug for pressure drop reading
B	Evaporator section
C	1-inch NPT female cond. drain connection
D	Filter access
E	Outdoor air compartment access

Item	Description
F	Outdoor air
G	Return air access
H	Return air
I	Supply air access
J	Supply air

Figure 6: ZT180-276 unit dimensions rear view

Figure 6 shows the unit dimensions for the rear view. The dimensions listed are for side duct flange opening. See field accessories for the side duct flange kit.

Duct covers

Units are shipped with the bottom duct openings covered. An accessory flange kit is available for connecting side ducts.

For a bottom duct application, complete the following steps.

1. Remove the side panels from the supply and return air compartments to gain access to the bottom supply and return air duct covers.
2. Remove and discard the bottom duct covers.

Duct openings are closed with sheet metal covers except when the unit includes a power exhaust option. The covering consists of a heavy black paper composition.

3. Replace the side supply and return air compartment panels.

For a side duct application, complete the following steps.

1. Replace the side panels on the supply and return air compartments with the accessory flange kit panels.
2. Connect ductwork to the flanges on those panels.

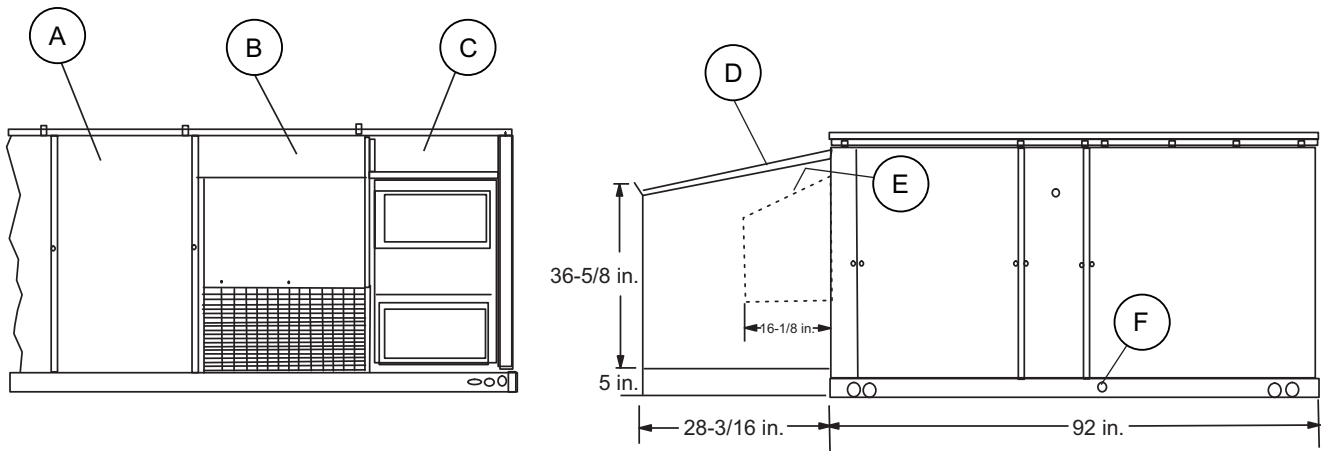

Rear view	
Item	Description
A	Supply air compartment
B	Power exhaust rain hood on the return air compartment
C	Economizer/motorized damper rain hood on the outdoor air compartment

LH view	
Item	Description
D	Economizer/motorized damper and power exhaust rain hood
E	Fixed outdoor air intake hood on the return air compartment
F	1 in. condensate drain. You must trap the drain.

Figure 7: ZT180-276 unit dimensions rain hood

Figure 7 shows detail Y of the unit with rain hoods installed.

Table 6: ZT180-276 unit clearances

Direction	Distance (in.)	Direction	Distance (in.)
Top ¹	72 with 36 maximum horizontal overhang (for condenser air discharge)	Right	36
Front	36	Bottom ²	0
Rear	24 (without an economizer)	Left	24 (without an economizer)
	49 (with an economizer)		36 (with an economizer) ³

- Units must be installed outdoors. Make sure that overhanging structure or shrubs do not obscure the condenser air discharge outlet.
- Units may be installed on combustible floors made from wood or class A, B or C roof covering materials.
- If an economizer is factory installed, the unassembled rain hood must be removed from its ride along position in front of the evaporator coil, or in the outdoor air compartment, prior to final installation.

Elec/elec model clearances

Units and ductwork are approved for zero clearance to combustible material when equipped with electric heaters.

Gas/elec model clearances

A 1 in. clearance must be provided between any combustible material and the supply air ductwork for a distance of 3 feet from the unit.

The products of combustion must not be allowed to accumulate within a confined space and recirculate.

Locate the unit so that the vent air outlet hood position meets the following conditions.

- It is at least three feet above any force air inlet located within 10 horizontal feet (excluding those integral to the unit).
- It is at least four feet below, four horizontal feet from, or one foot above any door or gravity air inlet into the building.
- It is at least four feet from electric and gas meters, regulators and relief equipment.

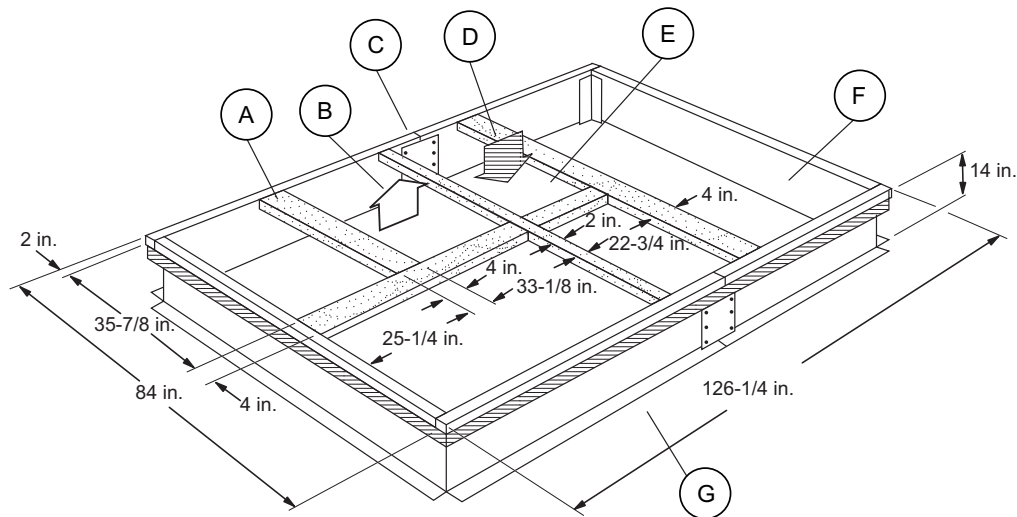

Item	Description
A	Duct support rails
B	Return air
C	Back of the unit
D	Supply air

Item	Description
E	Min. roof opening 39-7/8 in. wide x 61-7/8 in. long
F	Outdoor coil, end of the unit
G	Front of the unit

Figure 8: ZT180-276 roof curb

Figure 8 shows the ZT180-276 roof curb. The supply and return air and duct support rails shown are typical for bottom duct applications. For the location of horizontal duct applications see Figure 6. The following table lists the duct sizes.

Duct sizes

Duct	Size
Supply air	22-1/2 in. x 35-5/8 in.
Return air	32-7/8 in. x 35-5/8 in.

Ductwork

You must design and size ductwork according to the methods in Manual D of the Air Conditioning Contractors of America (ACCA) or as recommended by any other recognized authority such as ASHRAE or SMACNA. When you design the duct system, apply the following recommendations.

- Use a closed return duct system. This does not preclude the use of economizers or outdoor fresh air intake.
- Make the supply and return air duct connections at the unit with flexible joints to minimize noise.
- Design the supply and return air duct systems for the CFM and static pressure requirements of the job. Do not size them to match the dimensions of the duct connections on the unit.

See Figure 5 for bottom air duct openings. See Figure 6 for side air duct openings.

Note: In Canada, it is recommended that the outlet duct be provided with a removable access panel. It is recommended that this opening is accessible when the unit is installed in service, and of a size such that smoke or reflected light may be observed inside the

casing to indicate the presence of leaks in the heat exchanger. You must attach the cover in a manner adequate to prevent leakage.

Fixed outdoor air intake damper

This damper is shipped inside the return air compartment. It is completely assembled and ready for installation. A damper baffle inside of the hood is adjustable to provide variable amounts of outdoor air intake on units that are not provided with an economizer or a motorized damper option. See Figure 9 on page 14.

Gasketing and mounting screws are provided in a parts bag attached to the hood assembly.

Preparing the hood

Before you install the hood, complete the following step.

- Apply gasketing to the three flange surfaces on the hood. Extend the gasketing 1/4 inch beyond the top and bottom of the two side flanges to ensure adequate sealing.

Adjusting the damper

You may adjust the damper to the required air flow before you mount the hood into position or after installation. To adjust the damper, remove the front hood panel or the screen on the bottom of the hood. The following list describes the damper baffle positions.

- Position 1 provides approximately 10% outdoor air flow
- Position 2 provides approximately 15% outdoor air flow
- Removing the damper baffle provides approximately 25% outdoor air flow

Installing the damper

On units with a bottom return air application, complete the following steps.

1. Install the damper assembly over the opening in the side return air access panel.
2. Remove and discard the opening cover and the covering over the hood mounting holes (used for shipping).
3. Secure the assembly with the screws provided.

On units with a side return air application, complete the following steps.

1. Install the damper assembly on the return air ductwork as close to the unit as possible.
2. Cut an opening 16 inches high by 18 inches wide in the ductwork to accommodate the damper.
3. Using the holes in the hood flanges as a template, drill 9/64 inch diameter (#26 drill) holes into the ductwork
4. Secure the assembly with the screws provided.

⚠ CAUTION

If outdoor air intake is not required on units with bottom return air applications, mount the damper assembly on the side return air access panel according to the steps above. This ensures that moisture is not drawn into the unit during operation. Remove only the covering over the mounting holes. Do not remove the opening cover.

- Use a sealing compound on male pipe threads.
- Install a condensate drain line from the one-inch NPT female connection on the unit to an open drain.

Note: The condensate drain operates in a negative pressure in the cabinet. The condensate drain line must be trapped to provide proper drainage. See Figure 10.

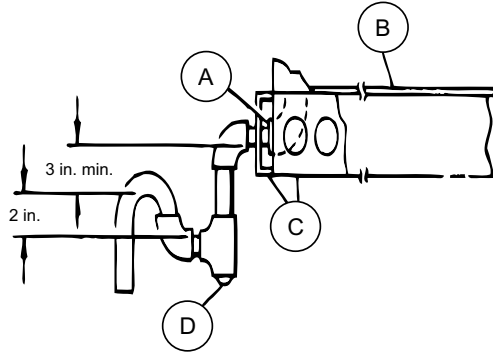

Item	Description	Item	Description
A	Unit condensate connection	C	Base rails
B	Base pan	D	Drain plug

Figure 10: Condensate drain

Compressors

The scroll compressor used in this product is specifically designed to operate with R-410A refrigerant and cannot be interchanged.

⚠ CAUTION

This system uses R-410A refrigerant which operates at higher pressures than R-22. No other refrigerant may be used in this system.

The compressor also uses a polyolester (POE oil), Mobil 3MA POE. This oil is extremely hygroscopic, meaning it absorbs water readily. POE oil can absorb 15 times as much water as other oils designed for HCFC and CFC refrigerants. Take all necessary precautions to avoid exposure of the oil to the atmosphere.

⚠ CAUTION

Do not leave the system open to the atmosphere. Unit damage could occur due to moisture being absorbed by the **POE oil** in the system. This type of oil is highly susceptible to moisture absorption

POE (polyolester) compressor lubricants are known to cause long term damage to some synthetic roofing materials.

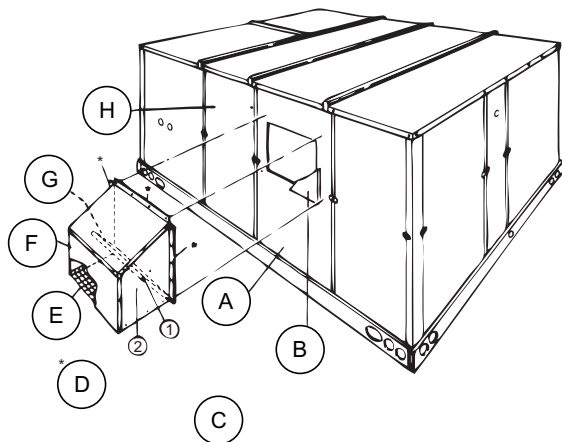

Item	Description	Item	Description
A	Side return air access panel	E	Screen
B	outdoor air opening cover	F	Hood
C	Rear view	G	Damper baffle
D	Gasketed flange	H	Side supply air access panel

Figure 9: Fixed outdoor air damper

Condensate drain

Plumbing must conform to local codes. Respect the following guidelines.

▲ CAUTION

Exposure, even if immediately cleaned up, may cause embrittlement (leading to cracking) to occur in one year or more. When you perform any service that may risk exposure of compressor oil to the roof, take precautions to protect roofing.

Procedures that risk oil leakage include, but are not limited to, the following:

- Compressor replacement
- Repairing refrigerant leaks
- Replacing refrigerant components such as the filter drier, pressure switch, metering device, or coil

Units are shipped with compressor mountings that are factory-adjusted and ready for operation.

▲ CAUTION

Do not loosen compressor mounting bolts.

Filters

Two-inch filters are supplied with each unit, but units can be converted easily to four-inch filters.

Always install filters ahead of evaporator coil. Keep the filters clean and replace them with filters of the same size and type. Dirty filters reduce the capacity of the unit and result in frosted coils or safety shutdown. See Table 9 on page 23 for the minimum filter area and required sizes.

▲ CAUTION

Make sure that panel latches are properly positioned on the unit to maintain an airtight seal.

Power and control wiring

Field wiring to the unit, fuses, and disconnects must conform to provisions of National Electrical Code (NEC), ANSI/NFPA No. 70 – latest edition (in U.S.A.), current Canadian Electrical Code C221, and/or local ordinances. The unit must be electrically grounded in accordance with NEC and CEC as specified above and/or local codes.

Voltage tolerances must be maintained at the compressor terminals during starting and running conditions. The voltage tolerances are indicated on the unit rating plate and Table 2.

▲ CAUTION

208/230-3-60 and 380/415-3-50 units control transformers are factory wired for 230v and 415v power supply respectively. Change the tap on the transformer for 208-3-60 or 380-3-50 operation. See the unit wiring diagram.

The internal wiring harnesses furnished with this unit are an integral part of the design certified unit. Field alteration to comply with electrical codes is not required.

If any of the wire supplied with the unit must be replaced, replacement wire must be of the type shown on the wiring diagram and the same minimum gauge as the replaced wire.

A disconnect must be used for these units. Factory-installed disconnects are available. If you install a field-supplied or York International® supplied disconnect, see Figure 1 for the recommended mounting location.

▲ CAUTION

Avoid damage to internal components if you drill holes to install a disconnect.

Note: Not all local codes allow the installation of a disconnect on the unit. Confirm compliance with local code before you install a disconnect on the unit.

Electrical line must be sized properly to carry the load.

Note: Use copper conductors only.

Each unit must be wired with a separate branch circuit fed directly from the meter panel and properly fused.

See Figures 11 and 12 for typical field wiring. Refer to the appropriate unit wiring diagram mounted inside control doors for control circuit and power wiring information.

▲ CAUTION

When you connect electrical power and control wiring to the unit, you must use water-proof connectors so that water or moisture cannot be drawn into the unit during normal operation. These water-proofing conditions also apply when you install a field-supplied disconnect switch.

Power wiring detail

Units are factory wired for the voltage shown on the unit nameplate. See Table 8, *Electrical data*, on page 18 to size power wiring, fuses, and the disconnect switch.

Power wiring is brought into the unit through the side of the unit or the basepan inside the curb.

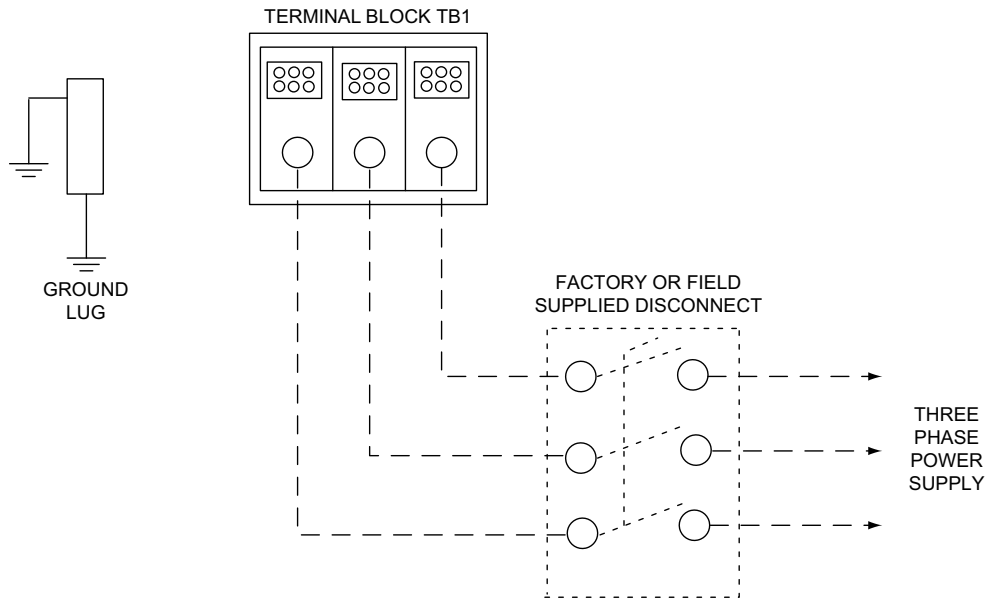

Figure 11: Field wiring disconnect - cooling unit with/without electric heat

Thermostat wiring

Install the thermostat on an inside wall approximately 56 inches above the floor. The thermostat must not be subject to drafts, sun exposure, or heat from electrical fixtures or appliances.

Follow the manufacturer's instructions enclosed with the thermostat for the general installation procedure. Use color-coded, insulated wires to connect the thermostat to the unit. See Table 7 for control wire sizing and maximum length.

⚠ CAUTION

208/230-3-60 and 380/415-3-50 units control transformers are factory wired for 230v and 415v power supply respectively. Change the tap on the transformer for 208-3-60 or 380-3-50 operation. See the unit wiring diagram.

Space sensor

If you use a space sensor, install the sensor on an inside wall approximately 56 inches above the floor. The sensor must not be subject to drafts, sun exposure, or heat from electrical fixtures or appliances.

Follow manufacturer's instructions enclosed with the sensor for the general installation procedure.

Table 7: Control wire sizes

Wire size	Maximum length ¹
18 AWG	150 feet

1. From the unit to the thermostat and back to the unit.

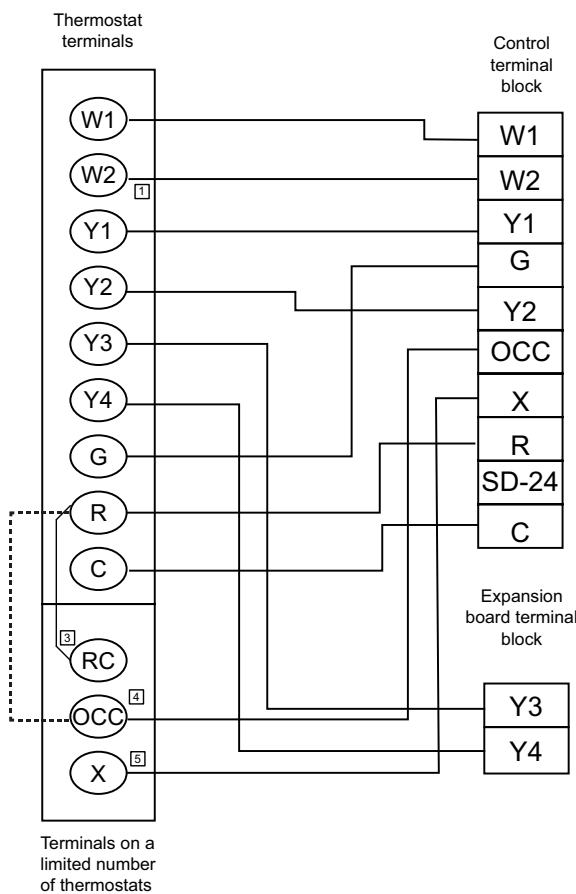

R~OCC jumper

Smart Equipment™ control boards come from the factory with a jumper wire between the R and OCC terminals on the thermostat terminal strip.

To enable thermostat or EMS control of the occupied mode for the unit, remove the jumper during commissioning.

If you do not remove the jumper, the unit remains in occupied mode regardless of the occupancy demand from the thermostat or EMS system.

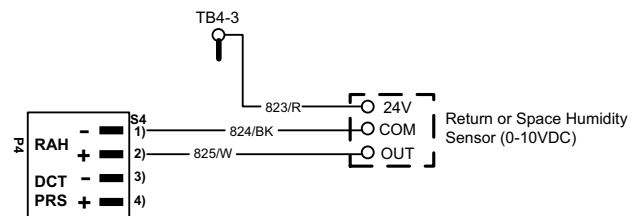
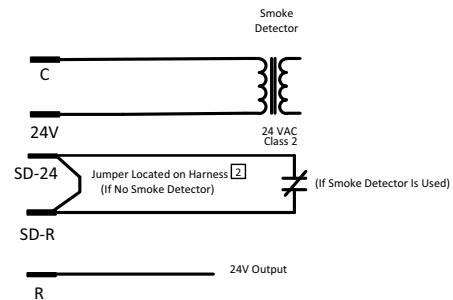

For units with optional reheat operation

- 1) Second stage heating not required on single stage heating units.
- 2) Jumper is required if there is no Smoke Detector circuit.
- 3) Jumper is required for any combination of R, RC, or RH.
- 4) OCC is an output from the thermostat to indicate the Occupied condition.
- 5) X is an input to the thermostat to display Error Status conditions.

Figure 12: Typical field wiring 24 volt thermostat

Table 8: Electrical data

ZT180-276 - standard drive without powered convenience outlet

Size (tons)	Volt	Compressors (each)									OD fan motors (each)	Supply blower motor	Pwr conv outlet	Electric heat				MCA ¹ (amps)	Max fuse ² / breaker ³ size (amps)
		RLA			LRA			MCC						Model	kW	Stages	Amps		
		C1	C2	C3	C1	C2	C3	C1	C2	C3									
180 (15)	208-3-60	25.3	25.3		184	184		40	40		3.5	13.5		None	-	-	-	84.4	100
														E18	13.5	1	37.5	84.4	100
														E36	27	2	74.9	110.5	125
														E54	40.6	2	112.7	157.8	175
	230-3-60	25.3	25.3		184	184		40	40		3.5	13		None	-	-	-	83.9	100
														E18	18	1	43.3	83.9	100
														E36	36	2	86.6	124.5	125
														E54	54	2	129.9	146.2	175
	460-3-60	9.6	9.6		84	84	15	15	15		1.6	6.5		None	-	-	-	34.5	40
														E18	18	1	21.7	35.3	40
														E36	36	2	43.3	62.3	70
														E54	54	2	65	73.1	80
210 (17.5)	208-3-60	26.9	28.8		164	223		42	45		5.3	20		None	-	-	-	104.1	125
														E118	13.5	1	37.5	104.1	125
														E136	27	2	74.9	118.6	125
														E154	40.6	2	112.7	165.9	175
	230-3-60	26.9	28.8		164	223		42	45		5.3	19.4		None	-	-	-	103.5	125
														E118	18	1	43.3	103.5	125
														E136	36	2	86.6	132.5	150
														E154	54	2	129.9	154.2	175
	460-3-60	12	12.5		94	100	15	19	20		2.5	9.7		None	-	-	-	47.3	50
														E18	18	1	21.7	47.3	50
														E36	36	2	43.3	66.3	70
														E54	54	2	65	77.1	90
240 (20)	208-3-60	32.6	16	23.2	240	110	164	51	25	36	5.3	20		None	-	-	-	121.2	150
														E118	13.5	1	37.5	121.2	150
														E136	27	2	74.9	121.2	150
														E154	40.6	2	112.7	165.9	175
	230-3-60	32.6	16	23.2	240	110	164	51	25	36	5.3	19.4		None	-	-	-	120.6	150
														E118	18	1	43.3	120.6	150
														E136	36	2	86.6	132.5	150
														E154	54	2	129.9	154.2	175
	460-3-60	14.8	7.8	11.2	130	52	75	23	12	18	2.5	9.7		None	-	-	-	57.2	70
														E18	18	1	21.7	57.2	70
														E36	36	2	43.3	66.3	70
														E54	54	2	65	77.1	90
276 (23)	208-3-60	35.4	15.6	25	240	110	164	55	24	39	5.3	26		None	-	-	-	132.1	150
														E118	13.5	1	37.5	132.1	150
														E136	27	2	74.9	132.1	150
														E154	40.6	2	112.7	173.4	175
	230-3-60	35.4	15.6	25	240	110	164	55	24	39	5.3	25		None	-	-	-	131.1	150
														E118	18	1	43.3	131.1	150
														E136	36	2	86.6	139.5	150
														E154	54	2	129.9	161.2	175
	460-3-60	16.5	7.8	12.2	140	52	100	26	12	19	2.5	12.5		None	-	-	-	63.1	70
														E18	18	1	21.7	63.1	70
														E36	36	2	43.3	69.8	70
														E54	54	2	65	80.6	90

1. Minimum Circuit Ampacity.
 2. Dual Element, Time Delay Type.
 3. HACR type per NEC.

ZT180-276 - standard drive with powered convenience outlet

Size (tons)	Volt	Compressors (each)									OD fan motors (each) FLA	Supply blower motor FLA	Pwr conv outlet FLA	Electric heat				MCA ¹ (amps)	Max fuse ² / breaker ³ size (amps)
		RLA			LRA			MCC						Model	kW	Stages	Amps		
		C1	C2	C3	C1	C2	C3	C1	C2	C3									
180 (15)	208-3-60	25.3	25.3		184	184		40	40		3.5	13.5	20	None	-	-	-	94.4	110
														E18	13.5	1	37.5	94.4	110
														E36	27	2	74.9	123	125
														E54	40.6	2	112.7	170.3	175
														E72	54.1	2	150.2	179.6	200
	230-3-60	25.3	25.3		184	184		40	40		3.5	13	20	None	-	-	-	93.9	110
														E18	18	1	43.3	93.9	110
														E36	36	2	86.6	137	150
														E54	54	2	129.9	158.7	175
														E72	72	2	173.2	202	225
	460-3-60	9.6	9.6		84	84		15	15		1.6	6.5	20	None	-	-	-	39.5	45
														E18	18	1	21.7	41.5	45
														E36	36	2	43.3	68.5	70
														E54	54	2	65	79.4	90
														E72	72	2	86.6	101	110
210 (17.5)	208-3-60	26.9	28.8		164	223		42	45		5.3	20	20	None	-	-	-	114.1	125
														E118	13.5	1	37.5	114.1	125
														E136	27	2	74.9	131.1	150
														E154	40.6	2	112.7	178.4	200
														E172	54.1	2	150.2	187.7	200
	230-3-60	26.9	28.8		164	223		42	45		5.3	19.4	20	None	-	-	-	113.5	125
														E118	18	1	43.3	113.5	125
														E136	36	2	86.6	145	150
														E154	54	2	129.9	166.7	175
														E172	72	2	173.2	210	225
	460-3-60	12	12.5		94	100		19	20		2.5	9.7	20	None	-	-	-	52.3	60
														E18	18	1	21.7	52.3	60
														E36	36	2	43.3	72.5	80
														E54	54	2	65	83.4	90
														E72	72	2	86.6	105	110
240 (20)	208-3-60	32.6	16	23.2	240	110	164	51	25	36	5.3	20	20	None	-	-	-	131.2	150
														E118	13.5	1	37.5	131.2	150
														E136	27	2	74.9	131.2	150
														E154	40.6	2	112.7	178.4	200
														E172	54.1	2	150.2	187.7	200
	230-3-60	32.6	16	23.2	240	110	164	51	25	36	5.3	19.4	20	None	-	-	-	130.6	150
														E118	18	1	43.3	130.6	150
														E136	36	2	86.6	145	150
														E154	54	2	129.9	166.7	175
														E172	72	2	173.2	210	225
	460-3-60	14.8	7.8	11.2	130	52	75	23	12	18	2.5	9.7	20	None	-	-	-	62.2	70
														E18	18	1	21.7	62.2	70
														E36	36	2	43.3	72.5	80
														E54	54	2	65	83.4	90
														E72	72	2	86.6	105	110
276 (23)	208-3-60	35.4	15.6	25	240	110	164	55	24	39	5.3	26	20	None	-	-	-	142.1	175
														E118	13.5	1	37.5	142.1	175
														E136	27	2	74.9	142.1	175
														E154	40.6	2	112.7	185.9	200
														E172	54.1	2	150.2	195.2	200
	230-3-60	35.4	15.6	25	240	110	164	55	24	39	5.3	25	20	None	-	-	-	141.1	175
														E118	18	1	43.3	141.1	175
														E136	36	2	86.6	152	175
														E154	54	2	129.9	173.7	175
														E172	72	2	173.2	217	225
	460-3-60	16.5	7.8	12.2	140	52	100	26	12	19	2.5	12.5	20	None	-	-	-	68.1	80
														E18	18	1	21.7	68.1	80
														E36	36	2	43.3	76	80
														E54	54	2	65	86.9	90
														E72	72	2	86.6	108.5	110

1. Minimum Circuit Ampacity.
2. Dual Element, Time Delay Type.
3. HACR type per NEC.

ZT180-276 - high static drive with powered convenience outlet

Size (tons)	Volt	Compressors (each)									OD fan motors (each) FLA	Supply blower motor FLA	Pwr conv outlet FLA	Electric heat				MCA ¹ (amps)	Max fuse ² / breaker ³ size (amps)
		RLA			LRA			MCC						Model	kW	Stages	Amps		
		C1	C2	C3	C1	C2	C3	C1	C2	C3									
180 (15)	208-3-60	25.3	25.3		184	184		40	40		3.5	20	20	None	-	-	-	100.9	125
														E18	13.5	1	37.5	100.9	125
														E36	27	2	74.9	131.1	150
														E54	40.6	2	112.7	178.4	200
	230-3-60	25.3	25.3		184	184		40	40		3.5	19.4	20	None	-	-	-	100.3	125
														E18	18	1	43.3	100.3	125
														E36	36	2	86.6	145	150
														E54	54	2	129.9	166.7	175
	460-3-60	9.6	9.6		84	84		15	15		1.6	9.7	20	None	-	-	-	42.7	50
														E18	18	1	21.7	45.5	50
														E36	36	2	43.3	72.5	80
														E54	54	2	65	83.4	90
210 (17.5)	208-3-60	26.9	28.8		164	223		42	45		5.3	26	20	None	-	-	-	120.1	125
														E118	13.5	1	37.5	120.1	125
														E136	27	2	74.9	138.6	150
														E154	40.6	2	112.7	185.9	200
	230-3-60	26.9	28.8		164	223		42	45		5.3	25	20	None	-	-	-	119.1	125
														E118	18	1	43.3	119.1	125
														E136	36	2	86.6	152	175
														E154	54	2	129.9	173.7	175
	460-3-60	12	12.5		94	100		19	20		2.5	12.5	20	None	-	-	-	55.1	60
														E18	18	1	21.7	55.1	60
														E36	36	2	43.3	76	80
														E54	54	2	65	86.9	90
240 (20)	208-3-60	32.6	16	23.2	240	110	164	51	25	36	5.3	26	20	None	-	-	-	137.2	150
														E118	13.5	1	37.5	137.2	150
														E136	27	2	74.9	138.6	150
														E154	40.6	2	112.7	185.9	200
	230-3-60	32.6	16	23.2	240	110	164	51	25	36	5.3	25	20	None	-	-	-	136.2	150
														E118	18	1	43.3	136.2	150
														E136	36	2	86.6	152	175
														E154	54	2	129.9	173.7	175
	460-3-60	14.8	7.8	11.2	130	52	75	23	12	18	2.5	12.5	20	None	-	-	-	65	70
														E18	18	1	21.7	65	70
														E36	36	2	43.3	76	80
														E54	54	2	65	86.9	90
276 (23)	208-3-60	35.4	15.6	25	240	110	164	55	24	39	5.3	37.2	20	None	-	-	-	153.7	175
														E118	13.5	1	37.5	153.7	175
														E136	27	2	74.9	153.7	175
														E154	40.6	2	112.7	199.9	200
	230-3-60	35.4	15.6	25	240	110	164	55	24	39	5.3	34.6	20	None	-	-	-	150.7	175
														E118	18	1	43.3	150.7	175
														E136	36	2	86.6	164	175
														E154	54	2	129.9	185.7	200
	460-3-60	16.5	7.8	12.2	140	52	100	26	12	19	2.5	17.3	20	None	-	-	-	73.1	90
														E18	18	1	21.7	73.1	90
														E36	36	2	43.3	82	90
														E54	54	2	65	92.9	100
460-3-60	16.5	7.8	12.2	140	52	100	26	12	19	2.5	17.3	20	None	-	-	-	73.1	90	
													E18	18	1	21.7	73.1	90	
													E36	36	2	43.3	82	90	
													E54	54	2	65	92.9	100	
460-3-60	16.5	7.8	12.2	140	52	100	26	12	19	2.5	17.3	20	None	-	-	-	73.1	90	
													E18	18	1	21.7	73.1	90	
													E36	36	2	43.3	82	90	
													E54	54	2	65	92.9	100	
460-3-60	16.5	7.8	12.2	140	52	100	26	12	19	2.5	17.3	20	None	-	-	-	73.1	90	
													E18	18	1	21.7	73.1	90	
													E36	36	2	43.3	82	90	
													E54	54	2	65	92.9	100	
460-3-60	16.5	7.8	12.2	140	52	100	26	12	19	2.5	17.3	20	None	-	-	-	73.1	90	
													E18	18	1	21.7	73.1	90	
													E36	36	2	43.3	82	90	
													E54	54	2	65	92.9	100	
460-3-60	16.5	7.8	12.2	140	52	100	26	12	19	2.5	17.3	20	None	-	-	-	73.1	90	
													E18	18	1	21.7	73.1	90	
													E36	36	2	43.3	82	90	
													E54	54	2	65	92.9	100	
460-3-60	16.5	7.8	12.2	140	52	100	26	12	19	2.5	17.3	20	None	-	-	-	73.1	90	
													E18	18	1	21.7	73.1	90	
													E36	36	2	43.3	82	90	
													E54	54	2	65	92.9	100	
460-3-60	16.5	7.8	12.2	140	52	100	26	12	19	2.5	17.3	20	None	-	-	-	73.1	90	
													E18	18	1	21.7	73.1	90	
													E36	36	2	43.3	82	90	
													E54	54	2	65	92.9	100	
460-3-60	16.5	7.8	12.2	140	52	100	26	12	19	2.5	17.3	20	None	-	-	-	73.1	90	
													E18	18	1	21.7	73.1	90	
													E36	36	2	43.3	82	90	
													E54	54	2	65	92.9	100	
460-3-60	16.5	7.8	12.2	140	52	100	26	12	19	2.5	17.3	20	None	-	-	-	73.1	90	
													E18	18	1	21.7	73.1	90	
													E36	36	2	43.3	82	90	
													E54	54	2	65	92.9	100	
460-3-60	16.5	7.8	12.2	140	52	100	26	12	19	2.5	17.3	20	None	-	-	-	73.1	90	
													E18	18	1	21.7	73.1	90	
													E36	36	2	43.3	82	90	
													E54	54	2	65	92.9	100	
460-3-60	16.5	7.8	12.2	140	52	100	26	12	19	2.5	17.3	20	None	-	-	-	73.1	90	
													E18	18	1	21.7	73.1	90	
													E36	36	2	43.3	82	90	
													E54	54	2	65	92.9	100	
460-3-60	16.5	7.8	12.2	140	52	100	26	12	19	2.5	17.3	20	None	-	-	-	73.1	90	
													E18	18	1	21.7	73.1	90	
													E36	36	2	43.3	82	90	
													E54	54	2	65	92.9	100	
460-3-60	16.5	7.8	12.2	140	52	100	26	12	19	2.5	17.3	20	None	-	-	-	73.1	90	
													E18	18	1	21.7	73.1	90	
													E36	36	2	43.3	82	90	
													E54	54	2	65	92.9	100	
460-3-60	16.5	7.8	12.2	140	52	100	26	12	19	2.5	17.3	20	None	-	-	-	73.1	90	
													E18	18	1	21.7	73.1	90	
													E36	36	2	43.3	82	90	
													E54	54	2	65	92.9	100	
460-3-60	16.5	7.8	12.2	140	52	100	26	12	19	2.5	17.3	20	None	-	-	-	73.1	90	
													E18	18	1	21.7	73.1	90	
													E36	36	2	43.3	82	90	
													E54	54	2	65	92.9	100	
460-3-60	16.5	7.8	12.2	140	52	100	26	12	19	2.5	17.3	20	None	-	-	-	73.1	90	
													E18	18	1	21.7	73.1	90	
													E36	36	2	43.3	82	90	
													E54	54	2	65	92.9	100	
460-3-60	16.5	7.8	12.2	140	52	100	26	12	19	2.5	17.3	20	None	-	-	-	73.1	90	
													E18	18	1	21.7	73.1	90	
													E36	36	2	43.3	82	90	
													E54	54	2	65	92.9	100	
460-3-60	16.5	7.8	12.2	140	52	100	26	12	19	2.5	17.3	20	None	-	-	-	73.1	90	
													E18	18	1	21.7	73.1	90	
													E36	36	2	43.3	82	90	
													E54	54	2	65	92.9	100	
460-3-60	16.5	7.8	12.2	140	52	100	26	12	19	2.5	17.3	20	None	-	-	-	73.1	90	
													E18	18	1	21.7	73.1	90	
													E36	36	2	43.3	82	90	
													E54	54	2	65	92.9	100	
460-3-60	16.5	7.																	

ZT276 - low static drive without powered convenience outlet

Size (tons)	Volt	Compressors (each)									OD fan motors (each)	Supply blower motor	Pwr conv outlet	Electric heat				MCA ¹ (amps)	Max fuse ² / breaker ³ size (amps)			
		RLA			LRA			MCC						FLA	FLA	FLA	Model			kW	Stages	Amps
		C1	C2	C3	C1	C2	C3	C1	C2	C3												
276 (23)	208-3-60	35.4	15.6	25	240	110	164	55	24	39	5.3	20		None	-	-	-	126.1	150			
														E118	13.5	1	37.5	126.1	150			
														E136	27	2	74.9	126.1	150			
														E154	40.6	2	112.7	165.9	175			
	230-3-60	35.4	15.6	25	240	110	164	55	24	39	5.3	19.4		None	-	-	-	125.5	150			
														E118	18	1	43.3	125.5	150			
														E136	36	2	86.6	132.5	150			
														E154	54	2	129.9	154.2	175			
	460-3-60	16.5	7.8	12.2	140	52	100	26	12	19	2.5	9.7		None	-	-	-	60.3	70			
														E18	18	1	21.7	60.3	70			
														E36	36	2	43.3	66.3	70			
														E54	54	2	65	77.1	90			
													E72	72	2	86.6	98.7	110				

1. Minimum Circuit Ampacity.
2. Dual Element, Time Delay Type.
3. HACR type per NEC.

ZT276 - low static drive with powered convenience outlet

Size (tons)	Volt	Compressors (each)									OD fan motors (each)	Supply blower motor	Pwr conv outlet	Electric heat				MCA ¹ (amps)	Max fuse ² / breaker ³ size (amps)			
		RLA			LRA			MCC						FLA	FLA	FLA	Model			kW	Stages	Amps
		C1	C2	C3	C1	C2	C3	C1	C2	C3												
276 (23)	208-3-60	35.4	15.6	25	240	110	164	55	24	39	5.3	20	20	None	-	-	-	136.1	150			
														E118	13.5	1	37.5	136.1	150			
														E136	27	2	74.9	136.1	150			
														E154	40.6	2	112.7	178.4	200			
	230-3-60	35.4	15.6	25	240	110	164	55	24	39	5.3	19.4	20	None	-	-	-	135.5	150			
														E118	18	1	43.3	135.5	150			
														E136	36	2	86.6	145	150			
														E154	54	2	129.9	166.7	175			
	460-3-60	16.5	7.8	12.2	140	52	100	26	12	19	2.5	9.7	20	None	-	-	-	65.3	80			
														E18	18	1	21.7	65.3	80			
														E36	36	2	43.3	72.5	80			
														E54	54	2	65	83.4	90			
													E72	72	2	86.6	105	110				

1. Minimum Circuit Ampacity.
2. Dual Element, Time Delay Type.
3. HACR type per NEC.

Table 9: ZT180-276 physical data

Component	Models							
	ZT180		ZT210		ZT240		ZT276	
Nominal tonnage	15		17.5		20		23	
ARI cooling performance								
Gross capacity @ ARI A point (BTU)	178000		198000		250000		275000	
ARI net capacity (BTU)	172000		192000		240000		265000	
EER	12.2 ¹ /12.0 ²		12.2 ¹ /12.0 ²		10.8/10.6 ²		10.2	
IEER with Intellispeed	18.0		17.0		16.0		15.5	
IEER with VAV	17.5		17.0		16.0		15.2	
CFM	5400		5400		6700		10000	
System power (KW)	14.20		15.86		21.98		25.60	
Refrigerant type	R-410a		R-410a		R-410a		R-410a	
Refrigerant charge (lb-oz)								
System 1	23-8		24-0		22-8		22-14	
System 2	24-0		24-8		25-0		23-10	
ARI heating performance								
Heating model	N30	N40	N30	N40	N30	N40	N30	N40
Heat input (K BTU)	300	400	300	400	300	400	300	400
Heat output (K BTU)	240	320	240	320	240	320	240	320
AFUE %	-	-	-	-	-	-	-	-
Steady state efficiency (%)	80	80	80	80	80	80	80	80
No. of burners	6	8	6	8	6	8	6	8
No. of stages	2	2	2	2	2	2	2	2
Temperature rise range (°F)	20-50	30-60	20-50	30-60	20-50	30-60	20-50	30-60
Gas limit setting (°F)	195	195	195	195	195	195	195	195
Gas piping connection (in.)	1	1	1	1	1	1	1	1
Dimensions (inches)								
Length	180-19/32							
Width	92							
Height	52-5/8							
Operating weight (lbs.)	2600		2730		2855		2925	
Compressors								
Type	Scroll		Scroll		Scroll		Scroll	
Quantity	2		2		3		3	
Unit capacity steps (%)	34 / 67 / 100		34 / 67 / 100		25 / 50 / 75 / 100		25 / 50 / 75 / 100	
Condenser coil data								
Face area (sq. ft.)	63.8		63.8		63.8		63.8	
Rows	2		2		2		2	
Fins per inch	20		20		20		20	
Tube diameter (in.)	3/8		3/8		3/8		3/8	
Circuitry type	Split-face		Split-face		Split-face		Split-face	
Evaporator coil data								
Face area (sq. ft.)	20.52		20		20		20.52	
Rows	4		4		4		4	
Fins per inch	14		14		14		14	
Tube diameter	3/8		3/8		3/8		3/8	
Circuitry type	Intertwined		Intertwined		Intertwined		Intertwined	
Refrigerant control	TXV		TXV		TXV		TXV	

Table 9: ZT180-276 physical data (continued)

Component	Models								
	ZT180		ZT210		ZT240		ZT276		
Nominal tonnage	15		17.5		20		23		
Condenser fan data									
Quantity	4		4		4		4		
Fan diameter (in.)	24		30		30		30		
Type	Prop		Prop		Prop		Prop		
Drive type	Direct		Direct		Direct		Direct		
No. of speeds	2		2		2		2		
Number of motors	4		4		4		4		
Motor HP each	1/3		1/2		1/2		1/2		
RPM	850/700		860/700		860/700		860/700		
Nominal total CFM	14000		17000		17000		17000		
Belt drive evaporator fan data									
Quantity	1		1		1		1		
Fan size (in.)	18 X 15		18 X 15		18 X 15		18 X 15		
Type	Centrifugal		Centrifugal		Centrifugal		Centrifugal		
Motor sheave	1VP60	1VP60	1VP60	1VP60	1VP60	1VP60	1VP60	1VP75X	1VP75X
Blower sheave	BK120	BK100	BK110	BK090	BK110	BK090	1B5V94	1B5V110	1B5V94
Belt	BX81	BX75	BX78	BX75	BX78	BX75	BX78	5VX840	5VX860
Motor HP each	5	7.5	7.5	10	7.5	10	7.5	10	15
RPM	1750	1770	1770	1770	1770	1770	1770	1770	1770
Frame size	184T	213T	213T	215T	213T	215T	213T	215T	254T
Filters									
Quantity - size	4 - (16 x 25 x 2)		4 - (16 x 25 x 2)		4 - (16 x 25 x 2)		4 - (16 x 25 x 2)		
	4 - (16 x 20 x 2) ^{3,4}		4 - (16 x 20 x 2) ^{3,4}		4 - (16 x 20 x 2) ^{3,4}		4 - (16 x 20 x 2) ^{3,4}		
	4 - (16 x 25 x 4)		4 - (16 x 25 x 4)		4 - (16 x 25 x 4)		4 - (16 x 25 x 4)		
	4 - (16 x 20 x 4) ⁵		4 - (16 x 20 x 4) ⁵		4 - (16 x 20 x 4) ⁵		4 - (16 x 20 x 4) ⁵		

1. Cooling only unit or cooling unit with electric heat.
2. Cooling unit with gas heat.
3. 2 in. throwaway, standard, MERV (Minimum Efficiency Reporting Value) 3.
4. 2 in. pleated, optional, MERV 8.
5. 4 in. pleated, optional, MERV 13.

Field-installed electric heat accessories

The field-installed heater accessories can be wired for single point power supply.

These CSA approved heater accessories are located within the central compartment of the unit with the heater elements extending into the supply air chamber.

Fuses are supplied, where required. Some kW sizes require fuses and others do not. See Table 10 for minimum CFM limitations. See Table 8 for electrical data.

Table 10: Electric heat minimum supply air

Size (tons)	Voltage	Minimum supply air (CFM)			
		Heater kW			
		18	36	54	72
180 (15)	208/230-3-60	4500	4500	5000	5000
	460-3-60	4500	4500	5000	4500
210 (17.5)	208/230-3-60	6000	6000	6000	6000
	460-3-60	6000	6000	6000	6000
240 (20)	208/230-3-60	6000	6000	6000	6000
	460-3-60	6000	6000	6000	6000
276 (23)	208/230-3-60	7500	7500	7500	7500
	460-3-60	7500	7500	7500	7500

Optional gas heat

The optional gas-fired heaters have aluminized-steel or optional stainless steel, tubular heat exchangers with spark ignition with proven pilot.

Table 11: Gas application data

Unit		Input (MBH)	Output (MBH)	Temp. rise (°F) ¹
Size	Opt.			
180	N30	300	240	20-50
	N40	400	320	30-60
210	N30	300	240	20-50
	N40	400	320	30-60
240	N30	300	240	20-50
	N40	400	320	30-60
276	N30	300	240	20-50
	N40	400	320	30-60

1. On VAV units, individual VAV boxes must be full open in heating mode to ensure airflow falls within the temperature rise range.

Gas piping

Proper sizing of gas piping depends on the cubic feet per hour of gas flow required, specific gravity of the gas, and the length of run.

Follow the "National Fuel Gas Code" Z223.1 (in U.S.A.) or the current Gas Installation Codes CSA-B149.1 (in Canada) in all cases unless superseded by local codes or gas utility requirements.

See Table 12, *Gas pipe sizing - capacity of pipe*, on page 25. The heating value of the gas may differ with locality. You must check the value with the local gas utility.

Note: There may be a local gas utility requirement specifying a minimum diameter for gas piping. All units require a one-inch pipe connection at the entrance fitting.

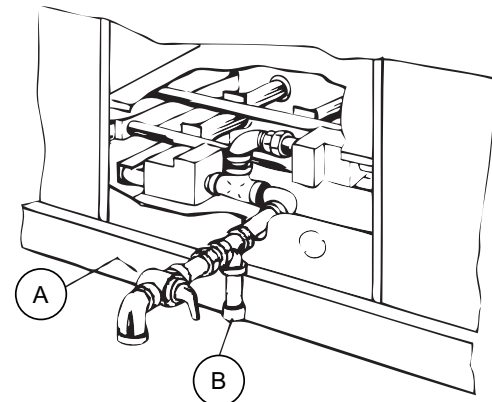

Item	Description
A	Main manual shut-off valve
B	Drip leg

Figure 13: External supply connection external shut-off

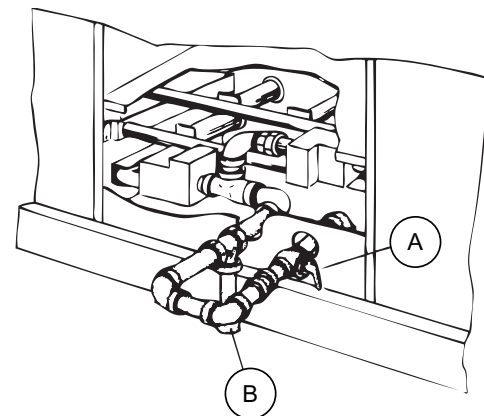

Item	Description
A	Main manual shut-off valve
B	Drip leg

Figure 14: Bottom supply connection external shut-off

Table 12: Gas pipe sizing - capacity of pipe

Length of pipe (ft.)	Nominal iron pipe size	
	1 in.	1-1/4 in.
10	520	1050
20	350	730
30	285	590
40	245	500
50	215	440
60	195	400
70	180	370
80	170	350
90	160	320
100	150	305

Note: Maximum capacity of pipe in cubic feet of gas per hour based upon a pressure drop of 0.3 inch W.C. and 0.6 specific gravity gas.

Table 13: Gas heat minimum supply air

Size (tons)	Heat size	Supply air (CFM)			
		Cooling		Heating	
		Min	Max	Min	Max
180 (15)	N30	4500	7000	4500	7000
	N40	4500	7000	5000	7000
210 (17.5)	N30	6000	8750	6000	8750
	N40	6000	8750	6000	8750
240 (20)	N30	6000	9400	6000	9400
	N40	6000	9400	6000	9400
276 (23)	N30	7500	12500	7500	12500
	N40	7500	12500	7500	12500

Gas connection

Route the gas supply line within the space and roof curb with the exit through the unit's basepan. See Figure 5 for the gas piping inlet location. Typical supply piping arrangements are shown in Figures 13 and 14. All pipe nipples, fittings, and the gas cock are field supplied.

Apply the following gas piping recommendations.

- You must install a drip leg and a ground joint union in the gas piping.
- When required by local codes, you must install a manual shut-off valve outside of the unit.
- Use wrought iron or steel pipe for all gas lines. Apply pipe dope sparingly to male threads only.

▲WARNING

Natural gas may contain some propane. Propane is an excellent solvent and quickly dissolves white lead and most standard commercial compounds. A special pipe dope must be used when assembling wrought iron or steel pipe. Shellac based compounds such as Gaskolac or Stalastic, and compounds such as Rectorseal #5, Clydes's or John Crane may be used.

- Clean all piping of dirt and scale. Hammer on the outside of the pipe and blow out loose particles. Before initial start-up, make sure that all gas lines external to the unit are purged of air.
- The gas supply must be a separate line and installed in accordance with all safety codes as prescribed under Limitations.
- You must install a 1/8-inch NPT plugged tapping, accessible for test gage connection, immediately upstream of the gas supply connection to the unit.
- After the gas connections are complete, open the main shut-off valve admitting *normal gas pressure* to the mains. *Check all joints for leaks with soap solution or other material suitable for the purpose. Never use a flame.*

▲WARNING

Fire or explosion hazard

Failure to follow the safety warning exactly could result in serious injury, death, or property damage.

Never test for gas leaks with an open flame. Use a commercially available soap solution made specifically for the detection of leaks to check all connections. A fire or explosion may result causing property damage, personal injury, or loss of life.

▲CAUTION

The furnace and its individual shut-off valve must be disconnected from the gas supply piping system during any pressure testing at pressures in excess of 1/2 PSIG. Pressures greater than 1/2 PSIG will cause gas valve damage resulting in a hazardous condition. If it is subjected to a pressure greater than 1/2 PSIG, the gas valve must be replaced.

The furnace must be isolated from the gas supply piping system by closing its individual manual shut-off valve during any pressure testing of the gas supply piping system at test pressures equal to or less than 1/2 PSIG.

▲WARNING

Threaded joints must be coated with a sealing compound that is resistant to the action of liquefied petroleum gases. **Do not use Teflon tape.**

LP units, tanks and piping

All gas heat units are shipped from the factory equipped for natural gas use only. The unit may be converted in the field for use with LP gas with accessory kit model number 1NP0418.

All LP gas equipment must conform to the safety standards of the National Fire Protection Association.

For satisfactory operation, LP gas pressure must be 10.0 inch W.C. at the unit under full load. Maintaining proper gas pressure depends on three main factors:

- The vaporization rate which depends on the temperature of the liquid and the wetted surface area of the containers.
- The proper pressure regulation. Two-stage regulation is recommended.
- The pressure drop in the lines between regulators and between the second stage regulator and the appliance. The pipe size required depends on the length of the pipe run and the total load of all appliances.

Complete information regarding tank sizing for vaporization, recommended regulator settings, and pipe sizing is available from most regulator manufacturers and LP gas suppliers.

WARNING

LP gas is an excellent solvent and quickly dissolves white lead and most standard commercial compounds. A special pipe dope must be used when assembling wrought iron or steel pipe for LP. Shellac base compounds such as Gaskolac or Stalastic, and compounds such as Rectorseal #5, Clyde's, or John Crane may be used.

Check all connections for leaks when the piping is completed using a soap solution. **Never use a flame.**

WARNING

Fire or explosion hazard
Failure to follow the safety warning exactly could result in serious injury, death or property damage.
Never test for gas leaks with an open flame. Use a commercially available soap solution made specifically for the detection of leaks to check all connections. A fire or explosion may result causing property damage, personal injury or loss of life.

Vent and combustion air

Two vent hoods and a combustion air hood with screens are shipped inside the gas heat section. A bag of screws for installation is attached to the blower housing. You must install these hoods to ensure proper unit function. See Figure 15.

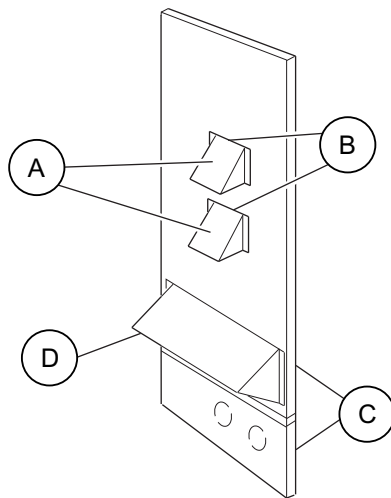

Item	Description	Item	Description
A	Vent air outlet hoods	C	Gas heat access panels
B	Slotted openings in access panel	D	Combustion air intake hood

Figure 15: Vent and combustion air hood

To install the hoods, complete the following steps.

Fasten all hoods to the outside of the gas heat access panel with the screws provided.

1. On the inside of the access panel, secure the screen for the combustion air intake hood to the opening with four fasteners and the screws provided. See Figure 15.
2. On the outside of the access panel, slide the top flange of the combustion air intake hood under the top of the opening. Secure with the screws provided.
3. Install the vent hoods.
 - a. On the outside of the access panel, insert the top flange of each vent hood into the slotted openings.
 - b. Secure the hoods with the screws provided.

The products of combustion are discharged horizontally through these two screened, hooded vent openings on the upper gas heat access panel.

Options and accessories**Electric heat**

Electric heaters are available as a field-installed accessory. The heaters mount in the heat compartment with the heating elements extending into the supply air chamber. All electric heaters are fused and intended for use with single point power supply.

Economizer/motorized outdoor damper rain hood

The instructions for the optional economizer/motorized damper rain hood are provided in the rain hood kit. Use these instructions when you field assemble an economizer rain hood onto a unit.

In the factory-installed economizer option, the outdoor and return air dampers, the damper actuator, the damper linkage, the outdoor and return air divider baffles, and all the control sensors are factory mounted.

Power exhaust/barometric relief damper and rain hood

The instructions for the power exhaust/barometric relief damper and rain hood are provided in the rain hood kit. The exhaust fan, all supporting brackets, angles, and the wiring are factory installed as part of the power exhaust option.

Economizer sequences

Several functions can drive the economizer, including: minimum position, free cooling, economizer loading, and minimum outdoor air supply.

Economizer minimum position

The economizer minimum position is set during occupied mode when outside air is not suitable for free cooling. The position of the damper is set proportionally between the economizer minimum position and the economizer minimum position low speed fan setpoints, in relationship to the VFD output percentage. On a constant volume single speed supply fan system, set both setpoints to the same value.

Free cooling

Four types of free cooling options are available: dry bulb changeover, single enthalpy, dual enthalpy changeover, and auto.

Dry bulb changeover

For dry bulb economizer operation, the outside air is suitable for free cooling if the outside air temperature is 1°F below the economizer OAT enable setpoint **and** 1°F below the return air temperature (RAT).

Free cooling is no longer available if the outside air temperature rises above **either** the economizer OAT enable setpoint **or** the return air temperature.

Single enthalpy changeover

For single enthalpy economizer operation, the outside air is suitable for free cooling if the outside air enthalpy is at least 1 BTU/lb below the economizer outside air enthalpy setpoint **and** the outside air temperature is no greater than the RAT plus 9°F.

If the outside air temperature rises above the RAT plus 10°F, free cooling is no longer available. The outside air temperature must drop to no greater than RAT plus 9°F to enter free cooling again.

Free cooling is no longer available if the outside air enthalpy rises above the economizer outside air enthalpy setpoint.

Dual enthalpy changeover

For dual enthalpy economizer operation, the outside air enthalpy must be lower than the return air enthalpy by 1 BTU/lb **AND** the outside air temperature is no greater than the RAT plus 9°F.

Auto

The control determines the type of free cooling changeover based on which sensors are present and reliable. Conditions include:

- Return and outside air dry bulb = dry bulb changeover
- Return and outside air dry bulb and outside air humidity = single enthalpy
- Return and outside air dry bulb and return and outside air humidity = dual enthalpy
- If either the return or outside air dry bulb sensors are unreliable, free cooling is not available

Free cooling operation

When the control determines that the outside air is suitable, the first stage of cooling will always be free cooling.

Thermostat

In free cooling, with a thermostat input to Y1, the dampers modulate to control the supply air temperature to the economizer setpoint +/- 1°F (default 55°F).

If the thermostat provides an input to Y2 **and** the parameter compressors off in free cooling is turned OFF a compressor output energizes. The economizer dampers continue to modulate to control the supply air temperature to the economizer setpoint.

If the supply air temperature cannot be maintained within 5°F of the economizer setpoint, the first stage compressor (C1) is turned on. Second stage compressor (C2) is added as needed to keep the supply air temperature within the 5°F of the economizer setpoint.

Sensor

In free cooling, with a demand from the zone/return sensor for the first stage of cooling, the dampers modulate to control the supply air temperature to the economizer setpoint +/- 1°F.

If the economizer output is at 100% **and** the SAT is greater than the economizer setpoint + 1°F, the control starts a 12-minute timer to energize a compressor output.

If at any time the economizer output drops below 100% the timer stops and resets when the economizer output returns to 100%.

Once a compressor output is turned ON, the economizer dampers continue to modulate to control the supply air temperature to the economizer setpoint.

At no time will a compressor output be turned ON if the economizer output is less than 100%, even if the differential between zone (or return) temperature and the current cooling setpoint is great enough to demand more than one stage of cooling.

If the economizer output goes to minimum position **and** the SAT is less than economizer setpoint -1°F, the control starts a 12-minute timer to de-energize a compressor output.

If at any time the economizer output goes above the minimum position the timer stops and resets when the economizer output returns to minimum position.

If the demand for cooling from the space/return is satisfied, the economizer output will modulate to minimum position and the compressor outputs will be de-energized as long as their minimum run timers have expired.

Power exhaust

Setpoints

- | | |
|--------------------------------------|-------------|
| a. Economizer enable | ON |
| b. Power exhaust enable | ON |
| c. Modulating power exhaust | OFF |
| d. Exhaust VFD installed | OFF |
| e. Building pressure sensor enabled | OFF |
| f. Econo damper position for exh fan | ON percent |
| g. Econo damper position for exh fan | OFF percent |

Inputs

No inputs are present for non-modulating power exhaust.

Outputs

- a. 2-10 VDC from ECON on economizer expansion module
- b. 24 VAC from EX-FAN to energize exhaust fan on economizer expansion module

Operation

Operation details include:

- a. Compares the economizer output to the economizer damper position for exhaust fan on and off.
- b. Energizes the exhaust fan when economizer output is above economizer damper position for exhaust fan on.
- c. De-energizes the exhaust fan when economizer output is below the economizer damper position for exhaust fan off.

Smart Equipment™ economizer board

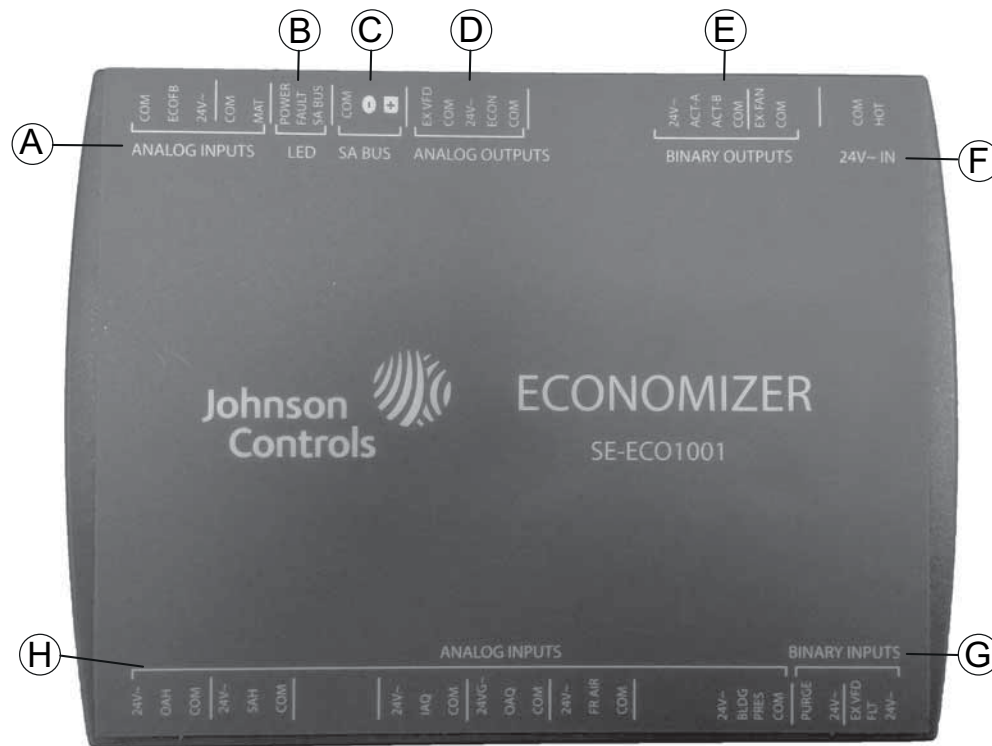

Figure 16: SE-ECO1001-0 economizer controller

The following tables describe the details of the economizer board. See Figure 16 for connection locations.

Smart Equipment™ economizer board - analog inputs

Location	Board label	Cover label	Description	Function and comments
A	C	COM	24 VAC common/0-10 VDC negative for economizer actuator position feedback	Connects through circuit trace to 24V~ IN pin COM
	IN2	ECOFB	0-10 VDC positive input from economizer actuator position feedback	The EconDampPos parameter reports input status (0-100%). Used to meet California Title 24 requirements for economizer actuator position feedback.
	R	24V~	24 VAC hot supplied for economizer actuator position feedback	Connects through circuit trace to 24V~ IN pin HOT
	IN1	MAT	Mixed air temperature sensor input from 10KΩ @ 77°F, Type III negative temperature coefficient thermistor	The MAT parameter reports input status (°F/°C), 3.65 VDC reading MAT (+) to COM (-) with open circuit. Read-only use in current control revision.
H	R	24V~	24 VAC hot supplied for the outdoor air humidity sensor	Connects through circuit trace to 24V~ IN pin HOT
	IN3	OAH	0-10 VDC positive input from the Outdoor Air Humidity sensor	OAH parameter reports input status (0-100%H). Used in outdoor air enthalpy calculation for dual enthalpy economizer free cooling changeover.
	C	COM	24 VAC common/0-10 VDC negative for the outdoor air humidity sensor	Connects through circuit trace to 24V~ IN pin COM
	R	24V~	24 VAC hot supplied for the supply air humidity sensor	Connects through circuit trace to 24V~ IN pin HOT
	IN4	SAH	0-10 VDC positive input from the Supply Air Humidity sensor	SAH parameter reports input status (0-100%H). Unused in current control revision.

Smart Equipment™ economizer board - analog inputs (continued)

Location	Board label	Cover label	Description	Function and comments
H	C	COM	24 VAC common/0-10 VDC negative for the supply air humidity sensor	Connects through circuit trace to 24V~ IN pin COM
	R	24V~	24 VAC hot supplied for the indoor air quality sensor	Connects through circuit trace to 24V~ IN pin HOT
	IN5	IAQ	0-10 VDC positive input from the Indoor Air Quality sensor	IAQRange parameter sets the CO2 parts per million measured by the indoor air quality sensor when it outputs 10 VDC; IAQ parameter reports input status (0-5000ppm). Used for demand ventilation functions if the NetIAQ parameter indicates ?Unrel.
	C	COM	24 VAC common/0-10 VDC negative for the indoor air quality sensor	Connects through circuit trace to 24V~ IN pin COM
	R	24V~	24 VAC hot supplied for the outdoor air quality sensor	Connects through circuit trace to 24V~ IN pin HOT
	IN6	OAQ	0-10 VDC positive input from the Outdoor Air Quality sensor	OAQRange parameter sets the CO2 parts per million measured by the outdoor air quality sensor when it outputs 10 VDC; OAQ parameter reports input status (0-5000ppm). Used for demand ventilation function when DVent-Mode selection is Diff between IAQ and OAQ and the NetOAQ parameter indicates ?Unrel.
	C	COM	24 VAC common/0-10 VDC negative for the outdoor air quality sensor	Connects through circuit trace to 24V~ IN pin COM
	R	24V~	24 VAC hot supplied for the air monitoring station sensor	Connects through circuit trace to 24V~ IN pin HOT
	IN7	FR AIR	0-10 VDC positive input from the air monitoring station sensor	MOA-Range parameter sets the cubic feet per minute/liters per second measured by the air monitoring station sensor when it outputs 10 VDC; Fr Air parameter reports input status (0-5000CFM/23595lps). Used for economizer minimum position reset in speed-controlled indoor blower applications.
	C	COM	24 VAC common/0-10 VDC negative for the air monitoring station sensor	Connects through circuit trace to 24V~ IN pin COM
	R	24V~	24 VAC hot supplied for the building pressure sensor	Connects through circuit trace to 24V~ IN pin HOT
	IN8	BLDG PRES	0-5 VDC positive input from the Building Pressure sensor	BldgPres parameter reports input status (-.250-.250"/w/-.062-.062kPa). Used for modulating power exhaust functions when ExFType selection is Modulating Damper or Variable Frequency Fan.
C	COM	24 VAC common/0-5 VDC negative for the building pressure sensor	Connects through circuit trace to 24V~ IN pin COM	

Smart Equipment™ economizer board - LED details

Location	Board label	Cover label	Description	Function and comments
B	POWER	POWER	Green UCB power indicator	Lit indicates 24 VAC is present at 24V~ IN COM and HOT pins
	FAULT	FAULT	Red networking error and firmware error indicator	1/10th second on/off flashing indicates a networking error (polarity, addressing, etc.) or a firmware error (likely correctable with re-loading from USB flash drive)
	SA BUS	SA BUS	Green UCB SA bus communication transmission indicator	Lit/flickering indicates UCB-to-economizer board SA bus communication is currently active, off indicates the economizer board is awaiting SA bus communication

Smart Equipment™ economizer board - SA bus details

Location	Board label	Cover label	Description	Function and comments
C ¹	C	COM	Common for SA BUS power and communication circuits	EconCtrlr parameter reports UCB-to-economizer board SA bus communication status. Negative of the SA BUS communication circuit to the UCB. Through the unit wiring harness, may continue on to the 4-stage board and/or fault detection & diagnostics board
	-	-	Communication for SA BUS devices	EconCtrlr parameter reports UCB-to-economizer board SA BUS communication status. Positive of the VDC (typically, a fluctuating 1.5 to 3.5 volts reading to C; at least 0.25 volts lower than +) SA BUS communication circuit to the UCB. Through the unit wiring harness, may continue on to the 4-stage board and/or fault detection & diagnostics board
	+	+	Communication for SA BUS devices	EconCtrlr parameter reports UCB-to-economizer board SA BUS communication status. Positive of the VDC (typically, a fluctuating 1.5 to 3.5 volts reading to C; at least 0.25 volts higher than -) SA BUS communication circuit to the UCB. Through the unit wiring harness, may continue on to the 4-stage board and/or fault detection & diagnostics board

1. When wiring the unit and other devices using the SA Bus and FC Bus, see Table 32.

Smart Equipment™ economizer board - analog outputs

Location	Board label	Cover label	Description	Function and comments
D	J4	EX VFD	2-10 VDC positive output for the modulating power Exhaust fan Variable Frequency Drive/ discharge damper modulating power exhaust actuator	ExFanVFD parameter reports output status (0-100%) when ExFType selection is Variable Frequency Fan; EAD-O parameter reports output status (0-100%) when ExFType selection is Modulating Damper. Used to ramp the power exhaust fan VFD/ position the discharge damper actuator.
		COM	24 VAC common/0-10 VDC negative for the power exhaust variable frequency drive/ discharge damper modulating power exhaust actuator	Connects through circuit trace to 24V~ IN pin COM
		24V~	24 VAC hot supplied for the discharge damper modulating power exhaust actuator and economizer actuator	Connects through circuit trace to 24V~ IN pin HOT
		ECON	2-10 VDC output for the Economizer actuator	Econ parameter reports output status (0-100%). Used to position the economizer actuator for minimum position, free cooling, demand ventilation, cooling economizer loading and purge functions
		COM	24 VAC common/0-10 VDC negative for economizer actuator	Connects through circuit trace to 24V~ IN pin COM

Smart Equipment™ economizer board - binary outputs

Location	Board label	Cover label	Description	Function and comments
E	J3	24V~	24 VAC hot supplied for an incremental (floating control) economizer actuator	Connects through circuit trace to 24V~ IN pin HOT
		ACT-A	24 VAC hot outputs to position an incremental (floating control) economizer actuator	Unused in current control revision
		ACT-B	24 VAC return	Unused in current control revision
		COM	24 VAC common for an incremental (floating control) economizer actuator	Connects through circuit trace to 24V~ IN pin COM
		EX-FAN	24 VAC hot output to energize power exhaust fan contactor coil/VFD enable relay coil	ExFan parameter reports output status (Off-On) when ExFType selection is Non-Modulating, Modulating Damper or Variable Frequency Fan. Used to turn on/enable the power exhaust fan motor.
		COM	24 VAC common/0-10 VDC negative for economizer actuator	Connects through circuit trace to 24V~ IN pin COM

Smart Equipment™ economizer board - 24V~ IN connections

Location	Board label	Cover label	Description	Function and comments
F	C	COM	24 VAC transformer Common referenced to cabinet ground	24 VAC common connection to power the economizer board. Connects through circuit traces to C/COM terminals and pins distributed on the economizer board.
		R	24 VAC transformer HOT	24 VAC hot connection to power the economizer board. Connects through circuit traces to R/24V~ terminals and pins distributed on the economizer board.

Smart Equipment™ economizer board - binary inputs

Location	Board label	Cover label	Description	Function and comments
G	IN9	PURGE	24 VAC hot input from the PURGE dry contact	Purge parameter reports input status (False with 0 VAC input-True with 24 VAC input). When Purge status is True, heating and cooling operation is prevented, the indoor blower and power exhaust fan operate, the economizer actuator is positioned to 100%.
		24V~	24 VAC hot supplied for the purge dry contact	Connects through circuit trace to 24V~ IN pin HOT
	IN10	EX VFD FLT	24 VAC hot input from the power Exhaust Variable Frequency Drive Fault contact	ExFanVFDFit parameter reports input status (Normal with 0 VAC input-Alarm with 24 VAC input) when ExFType selection is Variable Frequency Fan. When ExFanVFDFit status is Alarm, EX-FAN fan output is prevented.
		24V~	24 VAC hot supplied for the power exhaust variable frequency drive fault contact	Connects through circuit trace to 24V~ IN pin HOT

Power exhaust damper setpoint

With the power exhaust option, each building pressurization requirement is different. The point at which the power exhaust comes on is determined by the economizer damper position (percent open). Set the exhaust air adjustment screw at the percent open of the economizer damper at which the power exhaust is needed. It can be set from 0 to 100% damper open.

Indoor air quality

Indoor air quality (IAQ) is regulated by an indoor sensor input. The IAQ sensor is connected to the economizer board through

the IAQ analog input terminal and the associated COM and 24V~ inputs on the economizer board. Terminal IAQ accepts a 0 to +10 VDC signal with respect to the IAQ terminal. When the signal is below its setpoint, the actuator is allowed to modulate normally in accordance with the enthalpy and mixed air sensor inputs. When the IAQ signal exceeds its setpoint setting and there is no call for free cooling, the actuator is proportionately modulated from the 0 to 10 VDC signal, with 0 VDC corresponding to full closed and 10 VDC corresponding to full open. When there is no call for free cooling, the damper position is limited by the IAQ max. damper position setting. When the signal exceeds its setpoint (demand control

ventilation setpoint) setting and there is a call for free cooling, the actuator modulates from the minimum position to the full open position based on the highest call from either the mixed air sensor input or the IAQ voltage input.

- Optional CO² space sensor kit - part no. 2AQ04700524
- Optional CO² sensor kit - part no. 2AQ04700624

Adjusting the power exhaust damper setpoint for the optional BAS-ready economizer

With the power exhaust option, each building pressurization requirement is different. The point at which the power exhaust comes on is determined by the economizer's outdoor damper position.

1. Remove the economizer access panel from the unit.
2. Loosen the two panel latches but do not remove them.
3. Locate the economizer actuator, where the following adjustment can be made.
4. Set the actuator's auxiliary switch adjustment screw at the damper position at which the power exhaust is needed. You can set the adjustment screw between 25 to 85 degrees open.
5. Replace the economizer access panel.

Optional variable air volume

A variable air volume (VAV) option using a variable frequency drive (VFD) is available for applications requiring a constant supply duct static pressure. A differential pressure transducer is used to monitor supply duct static pressure and return a speed reference signal to the VFD to control the output of the indoor blower motor.

Duct static pressure transducer

A 0-5 in. WC pressure transducer, located in the control box compartment, is used to sense static (gauge) pressure in the supply air duct and convert this pressure measurement to a proportional 0-5 VDC electrical output. Pressure-transmitting plastic tubing (1/4 in. diameter) must be field supplied and installed from the transducer to both the ductwork and to the atmosphere.

Connect the tubing from the HIGH pressure tap of the transducer to a static pressure tap (field supplied) in the supply duct located at a point where constant pressure is expected. To prevent an unstable signal due to air turbulence, make sure that there are no obstructions, turns or VAV terminal boxes up- or down-stream of the sensing tube location for at least a distance of 6-10 times the duct diameter. Tubing must also be run between the LOW pressure tap of the transducer and atmospheric pressure (outside of the unit).

CAUTION

Do not run plastic tubing in the supply or return air ducts as air movement could cause erroneous pressure measurements. If the tubing penetrates through the bottom of the unit, be sure openings are sealed to prevent air and water leakage.

Factory-installed VFD

The factory-installed VFD is mounted in the blower access compartment. The drive comes wired from the factory to include both 3-phase power and control connections (run permit signal, speed reference signal, and fault signal). All required drive parameters are pre-programmed at the factory, except in the case of 208-volt applications.

For 208-volt applications, you must change the following parameters.

- Change the parameter that defines the motor nameplate voltage to a value of 208.00
- Change the parameter that defines motor-rated current to the appropriate value available on the motor's nameplate.

Refer to the enclosed drive material for instructions on changing parameter settings.

Manual bypass

An optional, factory-installed manual bypass switch is available with factory-installed VFD. The manual bypass switch is located in the blower motor access compartment. The manual bypass has the following three positions:

- **Drive** - routes power through the VFD for modulating control of the indoor blower motor.
- **Line (or bypass)** - routes power directly to the motor that provides full-speed motor operation and complete electrical isolation of the drive.
- **Test** - routes power to the VFD but not to the motor to allow for drive programming and diagnostics.

If a drive failure occurs, the unit does not automatically switch to bypass mode. You must set the manual bypass switch to the Line position. If there is a call for the fan, the indoor blower motor runs at full-speed while in the bypass mode.

CAUTION

If the unit is operated with the manual bypass switch in the Line (bypass) position and there are VAV boxes present in the duct system, then boxes must be driven to the full-open position using a customer-supplied power source to prevent over-pressurizing and possible damage to the ductwork.

WARNING

Before you begin any service, disconnect all power to the drive. Be aware that high voltages are present in the drive even after power is disconnected. Allow the capacitors within the drive to discharge before you begin service.

Hot gas bypass

Hot gas bypass (HGBP) is standard on all units with VAV.

To allow for low cooling load operation, a direct-acting, pressure-modulating bypass control valve installed on the system #1 discharge line is used to divert high temperature, high pressure refrigerant around the TXV in order to maintain a desired minimum evaporator pressure.

The opening pressure of the bypass valve is fully adjustable between 95 and 115 psig with a factory-setting of 105 psig.

Phasing

York® ZT units are properly phased at the factory. Check for proper compressor rotation. If the blower or compressors rotate in the wrong direction at start-up, the electrical connection to the unit is misphased. Change the phasing of the field line connection at the factory or field supplied disconnect to obtain proper rotation. Scroll compressors operate in only one direction. The scroll is misphased if it is drawing low amperage, has similar suction and discharge pressures, or it produces a high noise level.

CAUTION

Scroll compressors require proper rotation to operate correctly. Units are properly phased at the factory. Do not change the internal wiring to make the blower condenser fans, or compressor rotate correctly.

Blower rotation

Check for proper supply air blower rotation. If the blower is rotating backwards, the line voltage at the unit point of power connection is misphased. See *Phasing* on page 34.

Adjusting the belt tension

To adjust the belt tension complete the following steps.

1. Loosen the four belts nuts at the top and bottom. See Figure 17.

Note: Never loosen the static nut at the top of the adjustment bolt.

2. Turn the adjustment bolt.

3. Use a belt tension checker to apply a perpendicular force to one belt at the midpoint of the span shown in Figure 17. A deflection distance of 4 mm (5/32 in.) is obtained.
4. To determine the deflection distance from the normal position, use a straight edge from sheave to sheave as a reference line.

The recommended deflection force is as follows:

Tension new belts at the max. deflection force recommended for the belt section.

5. Re-tighten the belt nuts.

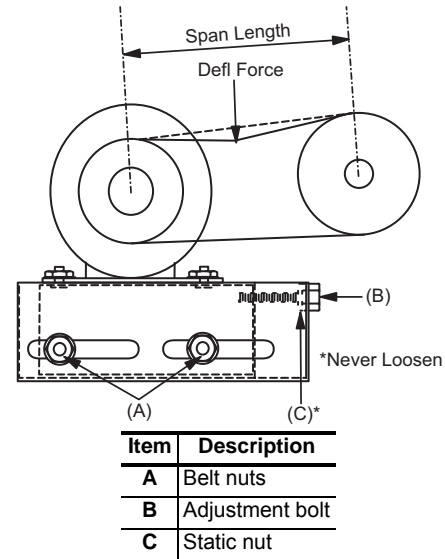

Figure 17: Belt adjustment

CAUTION

Check the belt tension at least two times during the first 24 hours of operation. Any retensioning should fall between the min. and max. deflection force values.

CFM static pressure and power-altitude and temperature corrections

Use the information below to assist in the application of the product at altitudes at or exceeding 1000 feet above sea level.

The air flow rates listed in the standard blower performance tables are based on standard air at sea level. As the altitude or temperature increases, the density of air decreases. In order to use the indoor blower tables for high altitude applications, certain corrections are necessary.

A centrifugal fan is a constant volume device. This means that, if the RPM remains constant, the CFM delivered is the same regardless of the density of the air. However, since the air at high altitude is less dense, less static pressure is generated and less power is required than a similar application at sea level. Air density correction factors are shown in Table 14 and Figure 18.

Table 14: Altitude/temperature correction factors

Air temp.	Altitude (ft.)										
	0	1000	2000	3000	4000	5000	6000	7000	8000	9000	10000
40	1.060	1.022	0.986	0.950	0.916	0.882	0.849	0.818	0.788	0.758	0.729
50	1.039	1.002	0.966	0.931	0.898	0.864	0.832	0.802	0.772	0.743	0.715
60	1.019	0.982	0.948	0.913	0.880	0.848	0.816	0.787	0.757	0.729	0.701
70	1.000	0.964	0.930	0.896	0.864	0.832	0.801	0.772	0.743	0.715	0.688
80	0.982	0.947	0.913	0.880	0.848	0.817	0.787	0.758	0.730	0.702	0.676
90	0.964	0.929	0.897	0.864	0.833	0.802	0.772	0.744	0.716	0.689	0.663
100	0.946	0.912	0.880	0.848	0.817	0.787	0.758	0.730	0.703	0.676	0.651

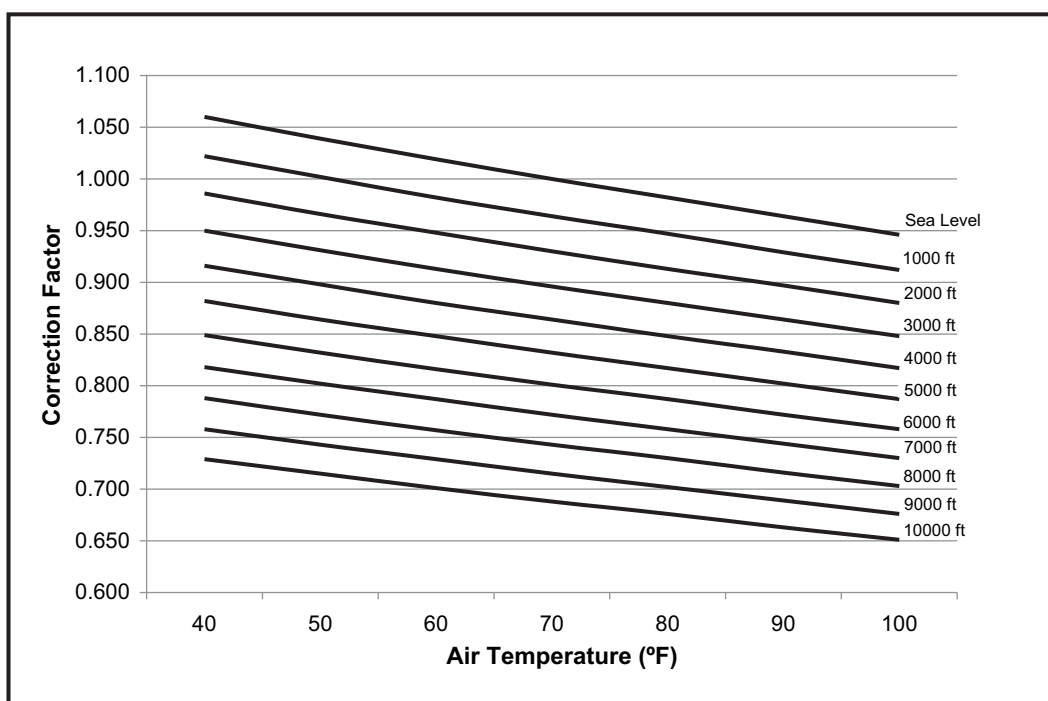
**Figure 18: Altitude/temperature correction factors**

Use the examples below to assist in determining the airflow performance of the product at altitude.

Example 1: What are the corrected CFM, static pressure, and BHP at an elevation of 5,000 ft. if the blower performance data is 6,000 CFM, 1.5 IWC and 4.0 BHP?

Solution: At an elevation of 5,000 ft. the indoor blower will still deliver 6,000 CFM if the rpm is unchanged. However, Table 14 must be used to determine the static pressure and BHP. We assume an air temperature of 70°F because no temperature data is given, Table 14 shows the correction factor to be 0.832.

$$\text{Corrected static pressure} = 1.5 \times 0.832 = 1.248 \text{ IWC}$$

$$\text{Corrected BHP} = 4.0 \times 0.832 = 3.328$$

Example 2: A system, located at 5,000 feet of elevation, is to deliver 6,000 CFM at a static pressure of 1.5 in. Use the unit

blower tables to select the blower speed and the BHP requirement.

Solution: As in the example above, no temperature information is given so 70°F is assumed.

The 1.5 in. static pressure given is at an elevation of 5,000 ft. The first step is to convert this static pressure to equivalent sea level conditions.

$$\text{Sea level static pressure} = 1.5 / .832 = 1.80 \text{ in.}$$

Enter the blower table at 6000 sCFM and static pressure of 1.8 in. The RPM listed is the same RPM needed at 5,000 ft.

Suppose that the corresponding BHP listed in the table is 3.2. This value must be corrected for elevation.

$$\text{BHP at 5,000 ft.} = 3.2 \times .832 = 2.66$$

Drive selection

1. Determine side or bottom supply duct application.
2. Determine the required airflow
3. Calculate or measure the amount of external static pressure.
4. Using the operating point determined from steps 1, 2, and 3, locate this point on the appropriate supply air blower performance table. Linear interpolation may be necessary.
5. Noting the RPM and BHP from step 4, locate the appropriate motor and/or drive on the RPM selection table.
6. Review the BHP compared to the motor options available. Select the appropriate motor and/or drive.
7. Review the RPM range for the motor options available. Select the appropriate drive if multiple drives are available for the chosen motor.
8. Determine turns open to obtain the desired operation point.

Example

1. 6800 CFM
2. 2.0 iwg
3. Using the supply air blower performance table below, the following data point was located: 1020 RPM and 5.92 BHP.
4. Using the RPM selection table below, Size X and Model Y is found.
5. 5.92 BHP exceeds the maximum continuous BHP rating of the 5.0 HP motor. The 7.5 HP motor is required.
6. 1020 RPM is within the range of the 7.5 HP drives.
7. Using the 7.5 HP motor and drive, 3.5 turns open achieves 1020 RPM.

Example supply air blower performance

Air flow (CFM)	Available external static pressure - IWG																							
	0.4		0.6		0.8		1.0		1.2		1.4		1.6		1.8		2.0		2.2		2.4		2.6	
	RPM	BHP	RPM	BHP	RPM	BHP	RPM	BHP	RPM	BHP	RPM	BHP	RPM	BHP	RPM	BHP	RPM	BHP	RPM	BHP	RPM	BHP	RPM	BHP
	Standard 5 HP and field supplied drive		Standard 5 HP and drive										High static 7.5 HP and drive											
6400	719	2.55	756	3.03	792	3.49	828	3.92	864	4.32	899	4.67	933	4.98	966	5.24	998	5.45	1028	5.59	1056	5.67	1083	5.68
6800	742	3.02	778	3.51	814	3.97	850	4.40	886	4.79	921	5.15	955	5.46	988	5.72	1020	5.92	1050	6.07	1078	6.15	1105	6.16
7200	765	3.54	802	4.03	838	4.49	874	4.92	910	5.32	945	5.67	979	5.98	1012	6.24	1044	6.44	1074	6.59	1102	6.67	1129	6.68
7600	790	4.11	827	4.60	863	5.06	899	5.49	935	5.88	970	6.24	1004	6.55	1037	6.81	1069	7.01	1099	7.16	1127	7.24	1154	7.25
																					7.5 HP and field supplied drive			

Table X: RPM selection

Size (tons)	Model	HP	Max BHP	Motor sheave	Blower sheave	6 turns open	5 turns open	4 turns open	3 turns open	2 turns open	1 turn open	Fully closed
X	Y	5	5.75	1VP60	BK110	730	765	800	835	870	905	N/A
		7.5	8.63	1VP60	BK090	905	950	990	1035	1075	1120	N/A

Table 15: Air flow performance - side duct application

ZT180 (15 ton) side duct

Air flow (CFM)	Available external static pressure - IWG ¹																									
	0.4		0.6		0.8		1		1.2		1.4		1.6		1.8		2		2.2		2.4		2.6			
	RPM	BHP	RPM	BHP	RPM	BHP	RPM	BHP	RPM	BHP	RPM	BHP	RPM	BHP	RPM	BHP	RPM	BHP	RPM	BHP	RPM	BHP	RPM	BHP	RPM	BHP
	Standard 5 HP and field supplied drive												Standard 5 HP and drive						High static 7.5 HP and drive							
4000	637	0.68	676	1.02	714	1.35	752	1.67	789	1.97	826	2.27	862	2.56	898	2.85	934	3.12	970	3.39	1005	3.66	1040	3.92		
4400	656	1.05	694	1.39	732	1.72	770	2.03	807	2.34	844	2.64	881	2.93	917	3.21	953	3.49	988	3.76	1023	4.03	1058	4.29		
4800	678	1.44	716	1.78	754	2.11	792	2.43	829	2.73	866	3.03	902	3.32	938	3.61	974	3.88	1010	4.15	1045	4.42	1080	4.68		
5200	702	1.87	740	2.21	778	2.54	816	2.86	853	3.16	890	3.46	927	3.75	963	4.04	999	4.31	1034	4.58	1069	4.85	1104	5.11		
5600	728	2.34	767	2.68	805	3.01	842	3.33	880	3.64	916	3.93	953	4.23	989	4.51	1025	4.79	1061	5.06	1096	5.32	1131	5.58		
6000	756	2.86	795	3.20	833	3.53	871	3.85	908	4.15	945	4.45	981	4.74	1017	5.03	1053	5.30	1089	5.57	1124	5.84	1159	6.10		
6400	786	3.43	824	3.77	862	4.10	900	4.41	937	4.72	974	5.02	1011	5.31	1047	5.59	1083	5.87	1118	6.14	1153	6.41	1188	6.67		
6800	817	4.05	855	4.38	893	4.71	931	5.03	968	5.34	1005	5.64	1041	5.93	1078	6.21	1113	6.49	1149	6.76	1184	7.02	1219	7.29		
7200	848	4.71	887	5.05	925	5.38	962	5.70	1000	6.00	1037	6.30	1073	6.59	1109	6.88	1145	7.15	1181	7.42	1216	7.69	1251	7.95		
7600	881	5.43	919	5.77	957	6.09	995	6.41	1032	6.72	1069	7.02	1106	7.31	1142	7.59	1178	7.87	1213	8.14	1248	8.40	-	-		
	High static 7.5 HP and field supplied drive																									

1. Blower performance includes gas heat exchangers and 2 in. filters. See the static resistance table for additional applications.
2. See the RPM selection table to determine the required motor sheave setting and to determine the maximum continuous BHP.
3. kW = BHP x 0.833.

ZT210 (17.5 ton) side duct

Air flow (CFM)	Available external static pressure - IWG ¹																									
	0.4		0.6		0.8		1		1.2		1.4		1.6		1.8		2		2.2		2.4		2.6			
	RPM	BHP	RPM	BHP	RPM	BHP	RPM	BHP	RPM	BHP	RPM	BHP	RPM	BHP	RPM	BHP	RPM	BHP	RPM	BHP	RPM	BHP	RPM	BHP	RPM	BHP
	Standard static 7.5 HP and field supplied drive												Standard 7.5 HP and drive													
4400	635	0.86	670	1.17	704	1.49	737	1.81	770	2.13	803	2.45	835	2.78	867	3.11	899	3.44	930	3.78	961	4.12	992	4.47		
4800	650	1.22	684	1.53	719	1.85	752	2.17	785	2.49	818	2.81	850	3.14	882	3.47	913	3.80	945	4.14	976	4.48	1007	4.83		
5200	668	1.61	702	1.93	737	2.24	770	2.56	803	2.88	836	3.21	868	3.53	900	3.86	931	4.19	963	4.53	994	4.87	1025	5.22		
5600	689	2.05	723	2.37	757	2.68	791	3.00	824	3.32	856	3.64	889	3.97	921	4.30	952	4.63	984	4.97	1015	5.31	1046	5.66		
6000	711	2.54	746	2.85	780	3.17	814	3.49	847	3.81	879	4.13	912	4.46	944	4.79	975	5.12	1007	5.46	1038	5.80	1069	6.15		
6400	736	3.08	771	3.39	805	3.71	839	4.03	872	4.35	904	4.67	937	5.00	968	5.33	1000	5.66	1031	6.00	1063	6.34	1094	6.69		
6800	763	3.68	798	3.99	832	4.31	865	4.63	898	4.95	931	5.27	963	5.60	995	5.93	1027	6.26	1058	6.60	1089	6.94	1120	7.29		
7200	791	4.33	825	4.65	860	4.96	893	5.28	926	5.60	959	5.92	991	6.25	1023	6.58	1054	6.91	1086	7.25	1117	7.59	1148	7.94		
7600	820	5.04	855	5.36	889	5.67	922	5.99	955	6.31	988	6.64	1020	6.96	1052	7.29	1084	7.63	1115	7.96	1146	8.31	1177	8.65		
8000	850	5.81	885	6.13	919	6.44	952	6.76	986	7.08	1018	7.40	1050	7.73	1082	8.06	1114	8.39	1145	8.73	1176	9.07	1207	9.42		
8400	881	6.64	916	6.95	950	7.27	984	7.59	1017	7.91	1049	8.23	1082	8.56	1113	8.88	1145	9.22	1176	9.56	1208	9.90	1239	10.25		
8800	913	7.52	948	7.83	982	8.15	1016	8.47	1049	8.79	1081	9.11	1114	9.44	1145	9.76	1177	10.10	1208	10.44	1240	10.78	1271	11.13		
	High static 10 HP and drive																									

1. Blower performance includes gas heat exchangers and 2 in. filters. See the static resistance table for additional applications.
2. See the RPM selection table to determine the required motor sheave setting and to determine the maximum continuous BHP.
3. kW = BHP x 0.813.

ZT240 (20 ton) side duct

Air flow (CFM)	Available external static pressure - IWG ¹																									
	0.4		0.6		0.8		1		1.2		1.4		1.6		1.8		2		2.2		2.4		2.6			
	RPM	BHP	RPM	BHP	RPM	BHP	RPM	BHP	RPM	BHP	RPM	BHP	RPM	BHP	RPM	BHP	RPM	BHP	RPM	BHP	RPM	BHP	RPM	BHP	RPM	BHP
	Standard static 7.5 HP and field supplied drive												Standard 7.5 HP and drive													
5200	668	1.61	702	1.93	737	2.24	770	2.56	803	2.88	836	3.21	868	3.53	900	3.86	931	4.19	963	4.53	994	4.87	1025	5.22		
5600	689	2.05	723	2.37	757	2.68	791	3.00	824	3.32	856	3.64	889	3.97	921	4.30	952	4.63	984	4.97	1015	5.31	1046	5.66		
6000	711	2.54	746	2.85	780	3.17	814	3.49	847	3.81	879	4.13	912	4.46	944	4.79	975	5.12	1007	5.46	1038	5.80	1069	6.15		
6400	736	3.08	771	3.39	805	3.71	839	4.03	872	4.35	904	4.67	937	5.00	968	5.33	1000	5.66	1031	6.00	1063	6.34	1094	6.69		
6800	763	3.68	798	3.99	832	4.31	865	4.63	898	4.95	931	5.27	963	5.60	995	5.93	1027	6.26	1058	6.60	1089	6.94	1120	7.29		
7200	791	4.33	825	4.65	860	4.96	893	5.28	926	5.60	959	5.92	991	6.25	1023	6.58	1054	6.91	1086	7.25	1117	7.59	1148	7.94		
7600	820	5.04	855	5.36	889	5.67	922	5.99	955	6.31	988	6.64	1020	6.96	1052	7.29	1084	7.63	1115	7.96	1146	8.31	1177	8.65		
8000	850	5.81	885	6.13	919	6.44	952	6.76	986	7.08	1018	7.40	1050	7.73	1082	8.06	1114	8.39	1145	8.73	1176	9.07	1207	9.42		
8400	881	6.64	916	6.95	950	7.27	984	7.59	1017	7.91	1049	8.23	1082	8.56	1113	8.88	1145	9.22	1176	9.56	1208	9.90	1239	10.25		
8800	913	7.52	948	7.83	982	8.15	1016	8.47	1049	8.79	1081	9.11	1114	9.44	1145	9.76	1177	10.10	1208	10.44	1240	10.78	1271	11.13		
9200	946	8.45	981	8.77	1015	9.08	1049	9.40	1082	9.72	1114	10.04	1146	10.37	1178	10.70	1210	11.03	1241	11.37	-	-	-	-		
9600	980	9.44	1014	9.75	1048	10.07	1082	10.39	1115	10.71	1148	11.03	1180	11.36	-	-	-	-	-	-	-	-	-	-		
	High static 10 HP and drive												High static 10 HP and field supplied drive													

1. Blower performance includes gas heat exchangers and 2 in. filters. See the static resistance table for additional applications.
2. See the RPM selection table to determine the required motor sheave setting and to determine the maximum continuous BHP.
3. kW = BHP x 0.813.

ZT276 (23 ton) side duct

Air flow (CFM)	Available external static pressure - IWG ¹																												
	0.4		0.6		0.8		1		1.2		1.4		1.6		1.8		2		2.2		2.4		2.6		2.8		3		
	RPM	BHP	RPM	BHP	RPM	BHP	RPM	BHP	RPM	BHP	RPM	BHP	RPM	BHP	RPM	BHP	RPM	BHP	RPM	BHP	RPM	BHP	RPM	BHP	RPM	BHP	RPM	BHP	RPM
	Low static 7.5 HP and field supplied drive						Low static 7.5 HP and drive						Standard static 10 HP and drive																
6600	780	2.75	811	3.40	841	3.96	887	4.45	900	4.88	930	5.28	960	5.64	990	5.99	1021	6.35	1053	6.72	1085	7.12	1120	7.57	1156	8.08	1193	8.67	
7000	800	3.43	831	4.08	861	4.64	891	5.13	920	5.56	950	5.95	980	6.32	1010	6.67	1041	7.02	1073	7.40	1106	7.80	1140	8.25	1176	8.76	1213	9.35	
7400	822	4.16	853	4.81	886	5.38	913	5.87	942	6.30	972	6.69	1002	7.06	1032	7.41	1063	7.76	1095	8.13	1128	8.54	1162	8.99	1198	9.50	1235	10.09	
7800	846	4.96	885	5.61	907	6.17	936	6.66	966	7.10	995	7.49	1025	7.85	1055	8.20	1086	8.56	1118	8.93	1151	9.33	1185	9.78	1221	10.30	1259	10.88	
8200	883	5.81	902	6.46	932	7.03	962	7.52	991	7.95	1021	8.34	1050	8.71	1081	9.06	1112	9.41	1143	9.78	1176	10.19	1211	10.64	1247	11.15	1284	11.74	
8600	898	6.72	929	7.37	959	7.94	989	8.43	1018	8.86	1048	9.25	1077	9.62	1108	9.97	1139	10.32	1170	10.69	1203	11.10	1238	11.55	1273	12.06	1311	12.65	
9000	926	7.69	957	8.34	987	8.90	1017	9.39	1047	9.82	1076	10.22	1106	10.59	1136	10.93	1167	11.29	1199	11.66	1232	12.06	1266	12.51	1302	13.02	1340	13.61	
9400	956	8.61	987	9.35	1017	9.92	1047	10.41	1077	10.84	1106	11.23	1136	11.60	1166	11.95	1197	12.30	1229	12.67	1262	13.08	1296	13.53	1332	14.04	1370	14.63	
9800	986	9.77	1019	10.42	1049	10.99	1079	11.48	1108	11.91	1138	12.30	1168	12.67	1198	13.02	1229	13.37	1261	13.74	1293	14.15	1328	14.60	1364	15.11	1401	15.70	
10200	1021	10.89	1052	11.49	1082	12.11	1112	12.60	1141	13.03	1171	13.42	1201	13.79	1231	14.14	1262	14.49	1294	14.86	1327	15.27	1361	15.72	1397	16.23	1434	16.82	
10600	1056	11.49	1087	12.71	1117	13.27	1146	13.77	1176	14.20	1205	14.59	1235	14.95	1266	15.31	1296	15.66	1328	16.03	1361	16.43	1395	16.89	-	-	-	-	
11000	1085	13.28	1123	13.93	1153	14.49	1182	14.98	1212	15.41	1242	15.81	1271	16.17	1302	16.52	1332	16.88	-	-	-	-	-	-	-	-	-	-	
	High static 15 HP and drive												High static 15 HP and field supplied drive																

1. Blower performance includes gas heat exchangers and 2 in. filters. See the static resistance table for additional applications.
2. See the RPM selection table to determine the required motor sheave setting and to determine the maximum continuous BHP.
3. kW = BHP x 0.813.

Table 16: Air flow performance - bottom duct application

ZT180 (15 ton) bottom duct

Air flow (CFM)	Available external static pressure - IWG ¹																									
	0.4		0.6		0.8		1		1.2		1.4		1.6		1.8		2		2.2		2.4		2.6			
	RPM	BHP	RPM	BHP	RPM	BHP	RPM	BHP	RPM	BHP	RPM	BHP	RPM	BHP	RPM	BHP	RPM	BHP	RPM	BHP	RPM	BHP	RPM	BHP	RPM	BHP
	Standard 5 HP and field supplied drive						Standard 5 HP and drive						High static 7.5 HP and drive													
4000	636	0.61	675	0.95	714	1.27	752	1.58	789	1.87	825	2.16	861	2.43	896	2.69	930	2.94	963	3.18	996	3.42	1029	3.65		
4400	658	0.93	698	1.27	737	1.60	775	1.90	812	2.20	848	2.48	884	2.75	918	3.01	952	3.26	986	3.50	1019	3.74	1051	3.97		
4800	683	1.33	722	1.66	761	1.99	799	2.29	836	2.59	872	2.87	908	3.14	943	3.40	977	3.65	1010	3.90	1043	4.13	1076	4.36		
5200	709	1.78	749	2.11	788	2.44	825	2.74	863	3.04	899	3.32	934	3.59	969	3.85	1003	4.10	1037	4.35	1070	4.58	1102	4.82		
5600	737	2.28	777	2.62	816	2.94	854	3.25	891	3.55	927	3.83	963	4.10	997	4.36	1032	4.61	1065	4.85	1098	5.09	1130	5.32		
6000	768	2.84	807	3.18	846	3.50	884	3.81	921	4.10	957	4.39	993	4.66	1028	4.92	1062	5.17	1095	5.41	1128	5.65	1161	5.88		
6400	800	3.45	840	3.79	879	4.11	916	4.42	954	4.71	990	4.99	1025	5.26	1060	5.52	1094	5.77	1128	6.02	1161	6.25	1193	6.49		
6800	834	4.10	874	4.44	913	4.76	951	5.07	988	5.36	1024	5.64	1060	5.91	1094	6.17	1128	6.42	1162	6.67	1195	6.90	1227	7.14		
7200	870	4.79	910	5.13	949	5.45	987	5.76	1024	6.05	1060	6.33	1096	6.60	1131	6.86	1165	7.11	1198	7.36	1231	7.60	1264	7.83		
7600	908	5.52	948	5.86	987	6.18	1025	6.49	1062	6.78	1098	7.06	1134	7.33	1169	7.59	1203	7.84	1236	8.09	1269	8.33	-	-	-	-
	High Static 7.5 HP and field supplied drive																									

1. Blower performance includes gas heat exchangers and 2 in. filters. See the static resistance table for additional applications.
2. See the RPM selection table to determine the required motor sheave setting and to determine the maximum continuous BHP.
3. kW = BHP x 0.833.

ZT210 (17.5 ton) bottom duct

Air flow (CFM)	Available external static pressure - IWG ¹																								
	0.4		0.6		0.8		1		1.2		1.4		1.6		1.8		2		2.2		2.4		2.6		
	RPM	BHP	RPM	BHP	RPM	BHP	RPM	BHP	RPM	BHP	RPM	BHP	RPM	BHP	RPM	BHP	RPM	BHP	RPM	BHP	RPM	BHP	RPM	BHP	RPM
	Standard static 7.5 HP and field supplied drive									Standard 7.5 HP and drive															
4400	641	0.87	677	1.24	712	1.58	746	1.89	780	2.19	813	2.47	846	2.76	879	3.05	912	3.35	944	3.67	978	4.02	1011	4.40	
4800	660	1.18	696	1.56	731	1.89	765	2.21	799	2.50	832	2.79	865	3.07	898	3.36	931	3.66	964	3.98	997	4.33	1031	4.72	
5200	681	1.56	717	1.93	752	2.27	787	2.58	821	2.88	854	3.16	887	3.45	920	3.73	952	4.04	985	4.36	1018	4.71	1052	5.09	
5600	705	1.99	741	2.36	776	2.70	810	3.02	844	3.31	877	3.60	910	3.88	943	4.17	976	4.47	1009	4.79	1042	5.14	1075	5.53	
6000	730	2.49	766	2.86	801	3.20	836	3.52	869	3.81	903	4.10	936	4.38	968	4.67	1001	4.97	1034	5.29	1067	5.64	1101	6.03	
6400	757	3.06	793	3.43	828	3.77	863	4.08	897	4.38	930	4.66	963	4.94	996	5.23	1028	5.53	1061	5.86	1094	6.21	1128	6.59	
6800	786	3.68	822	4.05	857	4.39	892	4.71	925	5.00	959	5.29	992	5.57	1025	5.86	1057	6.16	1090	6.48	1123	6.83	1157	7.22	
7200	817	4.37	853	4.74	888	5.08	922	5.40	956	5.69	989	5.98	1022	6.26	1055	6.55	1088	6.85	1121	7.17	1154	7.52	1188	7.91	
7600	849	5.12	885	5.49	920	5.83	955	6.15	988	6.44	1022	6.73	1055	7.01	1087	7.30	1120	7.60	1153	7.92	1186	8.27	1220	8.66	
8000	883	5.93	919	6.30	954	6.64	989	6.95	1022	7.25	1056	7.54	1088	7.82	1121	8.11	1154	8.41	1187	8.73	1220	9.08	1254	9.47	
8400	918	6.80	954	7.17	989	7.51	1024	7.82	1058	8.12	1091	8.40	1124	8.69	1157	8.98	1189	9.28	1222	9.60	1255	9.95	1289	10.33	
8800	955	7.72	991	8.09	1026	8.43	1060	8.74	1094	9.04	1127	9.33	1160	9.61	1193	9.90	1226	10.20	1259	10.52	1292	10.87	1326	11.25	
	High static 10 HP and drive									High static 10 HP and field supplied drive															

1. Blower performance includes gas heat exchangers and 2 in. filters. See the static resistance table for additional applications.
2. See the RPM selection table to determine the required motor sheave setting and to determine the maximum continuous BHP.
3. kW = BHP x 0.813.

ZT240 (20 ton) bottom duct

Air Flow (CFM)	Available external static pressure - IWG ¹																							
	0.4		0.6		0.8		1		1.2		1.4		1.6		1.8		2		2.2		2.4		2.6	
	RPM	BHP	RPM	BHP	RPM	BHP	RPM	BHP	RPM	BHP	RPM	BHP	RPM	BHP	RPM	BHP	RPM	BHP	RPM	BHP	RPM	BHP	RPM	BHP
	Standard static 7.5 HP and field supplied drive								Standard 7.5 HP and drive								High static 10 HP and drive							
5200	681	1.56	717	1.93	752	2.27	787	2.58	821	2.88	854	3.16	887	3.45	920	3.73	952	4.04	985	4.36	1018	4.71	1052	5.09
5600	705	1.99	741	2.36	776	2.70	810	3.02	844	3.31	877	3.60	910	3.88	943	4.17	976	4.47	1009	4.79	1042	5.14	1075	5.53
6000	730	2.49	766	2.86	801	3.20	836	3.52	869	3.81	903	4.10	936	4.38	968	4.67	1001	4.97	1034	5.29	1067	5.64	1101	6.03
6400	757	3.06	793	3.43	828	3.77	863	4.08	897	4.38	930	4.66	963	4.94	996	5.23	1028	5.53	1061	5.86	1094	6.21	1128	6.59
6800	786	3.68	822	4.05	857	4.39	892	4.71	925	5.00	959	5.29	992	5.57	1025	5.86	1057	6.16	1090	6.48	1123	6.83	1157	7.22
7200	817	4.37	853	4.74	888	5.08	922	5.40	956	5.69	989	5.98	1022	6.26	1055	6.55	1088	6.85	1121	7.17	1154	7.52	1188	7.91
7600	849	5.12	885	5.49	920	5.83	955	6.15	988	6.44	1022	6.73	1055	7.01	1087	7.30	1120	7.60	1153	7.92	1186	8.27	1220	8.66
8000	883	5.93	919	6.30	954	6.64	989	6.95	1022	7.25	1056	7.54	1088	7.82	1121	8.11	1154	8.41	1187	8.73	1220	9.08	1254	9.47
8400	918	6.80	954	7.17	989	7.51	1024	7.82	1058	8.12	1091	8.40	1124	8.69	1157	8.98	1189	9.28	1222	9.60	1255	9.95	1289	10.33
8800	955	7.72	991	8.09	1026	8.43	1060	8.74	1094	9.04	1127	9.33	1160	9.61	1193	9.90	1226	10.20	1259	10.52	1292	10.87	1326	11.25
9200	993	8.70	1029	9.07	1064	9.41	1098	9.72	1132	10.02	1166	10.30	1198	10.59	1231	10.87	1264	11.18	1297	11.50	-	-	-	-
9600	1032	9.73	1068	10.10	1103	10.44	1138	10.75	1172	11.05	1205	11.33	-	-	-	-	-	-	-	-	-	-	-	
	High static 10 HP and field supplied drive																							

1. Blower performance includes gas heat exchangers and 2 in. filters. See the static resistance table for additional applications.
2. See the RPM selection table to determine the required motor sheave setting and to determine the maximum continuous BHP.
3. kW = BHP x 0.813.

ZT276 (23 ton) bottom duct

Air Flow (CFM)	Available external static pressure - IWG ¹																											
	0.4		0.6		0.8		1		1.2		1.4		1.6		1.8		2		2.2		2.4		2.6		2.8		3	
	RPM	BHP	RPM	BHP	RPM	BHP	RPM	BHP	RPM	BHP	RPM	BHP	RPM	BHP	RPM	BHP	RPM	BHP	RPM	BHP	RPM	BHP	RPM	BHP	RPM	BHP	RPM	BHP
	Low static 7.5 HP and field supplied drive								Low static 7.5 HP and drive								Standard static 10 HP and drive											
6600	777	2.64	808	3.13	840	3.59	888	4.01	902	4.41	934	4.79	965	5.15	997	5.50	1028	5.84	1060	6.19	1092	6.53	1123	6.89	1155	7.26	1187	7.66
7000	800	3.31	832	3.80	863	4.26	894	4.69	925	5.08	957	5.46	988	5.82	1020	6.17	1051	6.52	1083	6.86	1115	7.21	1146	7.57	1178	7.94	1210	8.33
7400	825	4.05	856	4.54	887	5.00	919	5.42	950	5.82	981	6.20	1013	6.56	1044	6.91	1076	7.25	1108	7.59	1139	7.94	1171	8.30	1203	8.67	1235	9.07
7800	851	4.84	885	5.33	914	5.79	945	6.22	976	6.62	1008	6.99	1039	7.35	1071	7.70	1102	8.05	1134	8.39	1166	8.74	1197	9.10	1229	9.47	1261	9.86
8200	884	5.70	910	6.19	942	6.65	973	7.07	1004	7.47	1036	7.85	1067	8.21	1098	8.56	1130	8.90	1162	9.25	1193	9.59	1225	9.95	1257	10.32	1289	10.72
8600	909	6.61	940	7.10	971	7.56	1002	7.98	1033	8.38	1065	8.76	1096	9.12	1128	9.47	1159	9.82	1191	10.16	1223	10.51	1255	10.86	1286	11.24	1318	11.63
9000	939	7.58	971	8.07	1002	8.53	1033	8.95	1064	9.35	1096	9.73	1127	10.09	1159	10.44	1190	10.78	1222	11.13	1254	11.48	1285	11.83	1317	12.21	1349	12.60
9400	972	8.60	1003	9.10	1034	9.55	1065	9.98	1097	10.38	1128	10.75	1159	11.12	1191	11.46	1223	11.81	1254	12.15	1286	12.50	1318	12.86	1350	13.23	1382	13.62
9800	1005	9.68	1037	10.17	1068	10.63	1099	11.06	1130	11.45	1162	11.83	1193	12.19	1225	12.54	1256	12.89	1288	13.23	1320	13.58	1351	13.94	1383	14.31	1415	14.70
10200	1041	10.81	1072	11.30	1103	11.76	1134	12.18	1165	12.58	1197	12.96	1228	13.32	1260	13.67	1291	14.02	1323	14.36	1355	14.71	1387	15.06	1418	15.44	1450	15.83
10600	1107	11.99	1108	12.48	1139	12.94	1171	13.36	1202	13.76	1233	14.14	1265	14.50	1296	14.85	1328	15.19	1360	15.54	1391	15.89	1423	16.24	-	-	-	-
11000	1115	13.22	1146	13.71	1177	14.17	1208	14.59	1240	14.99	1271	15.37	1303	15.73	1334	16.08	1366	16.42	-	-	-	-	-	-	-	-	-	-
	High static 15 HP and drive														High static 15 HP and field supplied drive													

Table 17: RPM selection

Size (tons)	Model	HP	Max BHP	Motor sheave	Blower sheave	6 turns open	5 turns open	4 turns open	3 turns open	2 turns open	1 turn open	Fully closed
180 (15)	ZT	5.0	5.75	1VP60	BK120	721	752	783	814	844	875	N/A
		7.5	8.63	1VP60	BK100	885	923	960	998	1036	1073	N/A
210 (17.5)	ZT	7.5	8.63	1VP60	BK110	800	834	868	902	936	970	N/A
		10.0	11.5	1VP60	BK90	979	1021	1063	1104	1146	1188	N/A
240 (20)	ZT	7.5	8.63	1VP60	BK110	800	834	868	902	936	970	N/A
		10.0	11.5	1VP60	BK90	979	1021	1063	1104	1146	1188	N/A
276 (23)	ZT	7.5	8.63	1VP60	1B5V94	885	923	960	998	1036	1073	N/A
		10.0	11.5	1VP75X	1B5V110	986	1018	1050	1082	1114	1145	1177
		15.0	17.25	1VP75X	1B5V94	1154	1191	1229	1266	1303	1340	1378

Table 18: Indoor blower specifications

Size (tons)	Model	Motor					Motor sheave			Blower sheave			Belt
		HP	RPM	Eff.	SF	Frame	Datum dia. (in.)	Bore (in.)	Model	Datum dia. (in.)	Bore (in.)	Model	
180 (15)	ZT	5.0	1725	0.89	1.15	184T	4.3 - 5.5	1 1/8	1VP60	11.4	1 3/16	BK120	BX81
		7.5	1725	0.91	1.15	213T	4.3 - 5.5	1 3/8	1VP60	9.4	1 3/16	BK100	BX75
210 (17.5)	ZT	7.5	1725	0.91	1.15	213T	4.3 - 5.5	1 3/8	1VP60	10.4	1 3/16	BK110	BX78
		10.0	1725	0.91	1.15	215T	4.3 - 5.5	1 3/8	1VP60	8.4	1 3/16	BK090	BX75
240 (20)	ZT	7.5	1725	0.91	1.15	213T	4.3 - 5.5	1 3/8	1VP60	10.4	1 3/16	BK110	BX78
		10.0	1725	0.91	1.15	215T	4.3 - 5.5	1 3/8	1VP60	8.4	1 3/16	BK090	BX75
276 (23)	ZT	7.5	1725	0.91	1.15	213T	4.3 - 5.5	1 3/8	1VP60	9.4	1 7/16	1B5V94	BX78
		10.0	1725	0.91	1.15	215T	5.8 - 7.0	1 3/8	1VP75X	11.1	1 7/16	1B5V110	5VX840
		15.0	1725	0.93	1.15	254T	6.2 - 7.4	1 5/8	1VP75X	9.5	1 7/16	1B5V94	5VX840

Table 19: Power exhaust specifications

Voltage	Motor			Motor			CFM @ 0.1 ESP
	HP	RPM ¹	QTY	LRA	FLA	MCA	
208/230-1-60	3/4	1075	1	7.7	5.0	6.25	5250
460-1-60	3/4	1075	1	4.1	2.2	2.75	5250

1. Motors are multi-tapped and factory wired for high speed.

Air balance

⚠ CAUTION

On VAV units verify that the VFD drive is set to maximum output, exhaust dampers are closed, and individual space damper boxes are full open.

VFD units with bypass must not be in bypass mode (LINE position) unless all individual space dampers are full open.

Start the supply air blower motor. Adjust the resistances in both the supply and the return air duct systems to balance the air distribution throughout the conditioned space. The job specifications may require that this balancing be done by someone other than the equipment installer.

Checking air quantity

Check the supply air CFM after the initial balancing is completed.

1. Remove the two 5/16 in. dot plugs from the blower motor and the filter access panels. See Figures 5 and 6.
2. Insert at least 8 in. of 1/4 in. tubing into each of these holes for sufficient penetration into the air flow on both sides of the indoor coil.

Note: You must insert the tubes and hold them in a position perpendicular to the air flow so that velocity pressure does not affect the static pressure readings.

3. Use an inclined manometer to determine the pressure drop across a dry evaporator coil. The moisture on an evaporator coil may vary greatly, measuring the pressure drop across a wet coil under field conditions could be

inaccurate. To ensure that the coil is dry, deactivate the compressors while the test is being run.

Note: De-energize the compressors before taking any test measurements to ensure that the indoor coil is dry.

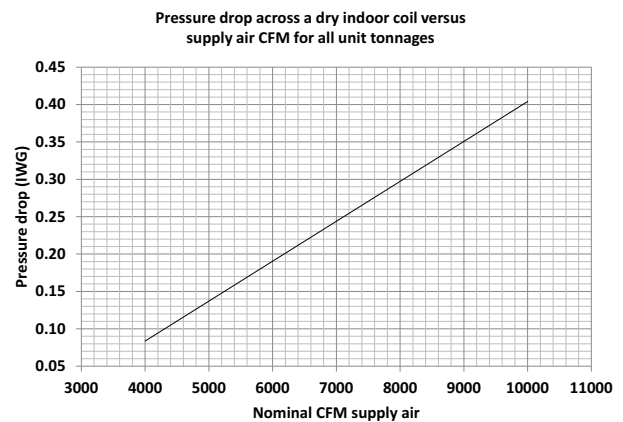

Figure 19: Pressure drop across a dry indoor coil vs. supply air CFM for all unit tonnages (does not include optional reheat coil)

4. Use the pressure drop across a dry coil, to determine the actual CFM through the unit from the curve in Figure 19.

⚠ WARNING

Failure to properly adjust the total system air quantity can result in extensive blower damage.

5. After you note the readings, remove the tubes and reinstall the two 5/16 in. dot plugs.

Supply air drive adjustment

The RPM of the supply air blower depends on the required CFM, the unit accessories or options, and the static resistances of both the supply and the return air duct systems. With this information, the RPM for the supply air blower and the motor pulley adjustment (turns open) can be determined from the blower performance data tables.

⚠ CAUTION

You must adjust belt drive blower systems to the specific static and CFM requirements for the application.

The belt drive blowers are not set at the factory for any specific static or CFM. Adjustments of the blower speed and belt tension are required. Tighten the blower pulley and motor sheave set screws after these adjustments. Re-check the set screws after 10-12 hours run time.

High speed drive accessories that contain a smaller blower pulley and a shorter belt are available for applications that require the supply air blower to produce higher CFMs and/or higher static pressures. The following models are available.

- Model 1LD0460 for 15 ton units
- model 1LD0417 for 17.5 and 20 ton units
- Model 1LD0435 for 25 ton units

See the blower motor and drive data table.

Note the following:

- The supply air CFM must be within the limitations shown in the blower performance tables 15 and 16.
- You can adjust pulleys in half turn increments.
- Adjust the belt tension as described in *Adjusting the belt tension* on page 34.
- Tighten the blower pulley and motor sheave set screws after any adjustments. Re-check the set screws after 10-12 hours run time.

Additional static resistance

Size (tons)	Model	CFM	Cooling only ¹	Reheat coil ²	Economizer ^{2 3}	Electric heat kW ²			
						18	36	54	72
180 (15) 210 (17.5) 240 (20) 276 (23)	ZT	4500	0.25	0.15	0.10	0.10	0.20	0.20	0.20
		6000	0.35	0.20	0.10	0.20	0.30	0.30	0.40
		7500	0.45	0.25	0.10	0.20	0.30	0.40	0.40
		9000	0.50	0.30	0.15	0.50	0.50	0.70	0.80
		10500	0.55	0.40	0.15	0.70	0.80	0.90	0.90
		11000	0.60	0.45	0.20	0.80	0.90	1.00	1.00

1. Add these values to the available static resistance in the respective blower performance tables.
2. Deduct these values from the available external static pressure shown in the respective blower performance tables.
3. The pressure drop through the economizer is greater for 100% outdoor air than for 100% return air. If the resistance of the return air duct is less than 0.25 IWG, the unit delivers less CFM during full economizer operation.

Sequence of operation

Cooling sequence of operation

Note: The lead-lag compressor equalization feature must remain off on all ZT 15-23 ton models. The default is OFF.

ZT180-210 units

A Y1 call for the first stage of cooling is passed to the unit control board (UCB). The UCB then determines whether the requested operation is available and if so, which components to energize. With a Y1 call for first stage cooling the UCB determines if a first stage cooling output is valid as long as all safeties and time-delays allow a C1 output for cooling. The C1 relay on the UCB closes and sends 24 volts to the M1 relay starting compressor #1 on low speed and also energizing terminal block TB3-1 for Cond. Fan #1 and Cond. Fan #2 on low speed. The UCB energizes the VFD equipped blower at the first stage speed as set in the Smart Equipment™ control.

If a Y2 call is present, it is passed to the UCB. The UCB then determines whether the requested operation is available and if so, which components to energize. With a Y2 call for second stage cooling the UCB determines if a second stage cooling output is valid as long as all safeties and time-delays allow a C2 output for cooling. The C2 relay on the UCB closes and sends 24 volts to the M2 relay starting compressor #2 on low speed and also energizing terminal block TB3-2 for Cond. Fan #3 and Cond. Fan #4 on low speed. The UCB energizes the VFD equipped blower at the second stage speed as set in the Smart Equipment™ control.

If a Y3 call is present, it is passed to the UCB. The UCB then determines whether the requested operation is available and if so, which components to energize. With a Y3 call for third stage cooling the UCB determines if a third stage cooling output is valid as long as all safeties and time-delays allow a C3 output for cooling. The C3 relay on the UCB closes and sends 24 volts to the terminal block TB-3 which energizes compressors #1 and #2 on high speed and also Cond. Fan #1, Cond. Fan #2, Cond. Fan #3, and Cond. Fan #4 on high speed. The UCB energizes the VFD equipped blower at the third stage speed as set in the Smart Equipment™ control.

ZT240-276 units

A Y1 call for the first stage of cooling is passed to the UCB. The UCB then determines whether the requested operation is available and if so, which components to energize. With a Y1 call for first stage cooling the UCB determines if a first stage cooling output is valid as long as all safeties and time-delays allow a C1 output for cooling. The C1 relay on the UCB closes and sends 24 volts to the M1 relay starting compressor #1 and also energizing terminal block TB3-1 for Cond. Fan #1 and Cond. Fan #2 on low speed. The UCB energizes the VFD equipped blower at the first stage speed as set in the Smart Equipment™ control.

If a Y2 call is present, it is passed to the UCB. The UCB then determines whether the requested operation is available and if so, which components to energize. With a Y2 call for second stage cooling the UCB determines if a second stage cooling

output is valid as long as all safeties and time-delays allow a C2 output for cooling. The C2 relay on the UCB closes and sends 24 volts to the M2 relay starting compressor #2 on low speed and also energizing terminal block TB3-2 for Cond. Fan #3 and Cond. Fan #4 on low speed. The UCB energizes the VFD equipped blower at the second stage speed as set in the Smart Equipment™ control.

If a Y3 call is present, it is passed to the UCB. The UCB then determines whether the requested operation is available and if so, which components to energize. With a Y3 call for third stage cooling the UCB determines if a third stage cooling output is valid as long as all safeties and time-delays allow a C3 output for cooling. The C3 relay on the UCB closes and sends 24 volts to the terminal block TB-3 which energizes compressor #2 on high speed and also Cond. Fan #3 & Cond. Fan #4 on high speed. The UCB energizes the VFD equipped blower at the third stage speed as set in the Smart Equipment™ control.

If a Y4 call is present, it is passed to the UCB. The UCB then determines whether the requested operation is available and if so, which components to energize. With a Y4 call for fourth stage cooling the UCB determines if a fourth stage cooling output is valid as long as all safeties and time-delays allow a C4 output for cooling. The C4 relay on the UCB closes and sends 24 volts to the M11 relay starting compressor #3 also energizing terminal block TB5 for Cond. Fan #1 and Cond. Fan #2 on high speed. The UCB energizes the VFD equipped blower at the fourth stage speed as set in the Smart Equipment™ control.

Continuous blower

When the room thermostat fan switch is set to ON, the supply air blower operates continuously.

Intermittent blower

With the room thermostat fan switch set to AUTO and the system switch set to either the AUTO or HEAT settings, the blower is energized whenever a cooling or heating operation is requested. The blower is energized after any specified delay associated with the operation.

When energized, the indoor blower has a minimum run time of 30 seconds. Additionally, the indoor blower has a minimum off delay of 10 seconds.

Optional VAV startup and control

CAUTION

If the unit is operated with the manual bypass switch in the LINE (BYPASS) position and there are VAV boxes present in the duct system, then boxes must be driven to the full-open position using a customer-supplied power source to prevent over-pressurizing and possible damage to the ductwork.

For units with VFD and VAV control, you must put the unit into the occupied mode to start operation. The default setting for all VAV units is unoccupied, therefore the installer must either keep the jumper wire between terminals R - OCC or use

network communication of a BAS control system to switch between unoccupied and occupied modes.

When placed into the occupied mode, the speed of the indoor blower motor is controlled by duct static pressure. The duct static setpoint (default = 1.5 in.) is the pressure that the VFD drive maintains when operating the unit in VAV mode. If the duct static pressure reaches or exceeds the high-limit setpoint (default = 4.5 in.), then the supply fan motor is shutdown.

The supply air temperature (SAT) is controlled by staging compressors on and off to satisfy the operating cooling supply air temp setpoint. There are three setpoints that determine the resulting operating cooling supply air temp setpoint.

1. VAV cooling supply air temp upper setpoint (default 60°F)
2. VAV cooling supply air temp lower setpoint (default 55° F)
3. VAV supply air temp reset setpoint (default 72°F)

When the return air temp (RAT) is above the VAV supply air temp reset setpoint, the SAT is maintained at +/- 5 degrees of the VAV cooling supply air temp lower setpoint.

When the return air temp (RAT) is below the VAV supply air temp reset setpoint, the SAT is maintained at +/- 5 degrees of the VAV cooling supply air temp upper setpoint.

When the outdoor air condition is sufficient for free cooling, the economizer modulates to control the SAT to +/- 1 degrees of the operational setpoint.

Cooling operation errors

Each cooling system is monitored for operation outside of the intended parameters. Errors are handled as described below. All system errors override minimum run times for compressors.

Note: The following components are needed to access the control points in the Smart Equipment™ control.

1. Local LCD on the unit control board.
OR
2. Mobile Access Portal (MAP) Gateway (portable).
 - Source 1 P/N S1-YK-MAP1810-0P
 - MAP Gateway Quick Start Guide P/N 24-10737-16
 - MAP Gateway Instruction P/N 24-10737-8

High-pressure limit switch

During cooling operation, if a high-pressure limit switch opens, the UCB de-energizes the associated compressor, initiates the ASCD (anti-short cycle delay), and, if the other compressor is idle, stops the condenser fans. If the call for cooling is still present at the conclusion of the ASCD, the UCB re-energizes the halted compressor.

If a high-pressure switch opens three times within two hours of operation, the UCB locks out the associated compressor. If the other compressor is inactive, the condenser fans are de-energized.

Low-pressure limit switch

The low-pressure limit switch is not monitored during the initial 30 seconds of a cooling system's operation. For the following 30 seconds, the UCB monitors the low-pressure switch to ensure it closes. If the low-pressure switch fails to close after the 30-second monitoring phase, the UCB de-energizes the associated compressor, initiates the ASCD, and, if the other compressor is idle, stops the condenser fans. If the LPS is still open after the ASCD, the compressor is not be energized for 30 seconds. The second and third times that the UCB sees an open LPS counts towards the three occurrences that cause a UCB lock-out.

When the low-pressure switch is proven (closed during the 30-second monitor period described above), the UCB monitors the low-pressure limit switch for any openings. If the low-pressure switch opens for greater than 5 seconds, the UCB de-energizes the associated compressor, initiates the ASCD, and, if the other compressor is idle, stops the condenser fans.

If the call for cooling is still present at the conclusion of the ASCD, the UCB re-energizes the halted compressor.

If a low-pressure switch opens three times within one hour of operation, the UCB locks out the associated compressor. If the other compressor is inactive, the condenser fans are de-energized.

Evaporator low limit

The evaporator low limit sensor is located on the suction line at the evaporator coil.

During cooling operation, if the evaporator low limit sensor (EC1, 2) detects a temperature below 26°F (default), the UCB de-energizes the associated compressor, initiates the ASCD, and, if the other compressor is idle, stops the condenser fans. If the call for cooling is still present at the conclusion of the ASCD, the UCB re-energizes the halted compressor. If the UCB detects the evaporator low limit sensor (EC1, 2) falling below 26°F (default) three times within two hours of operation, the UCB locks out the associated compressor. If the other compressor is inactive, the condenser fans are de-energized.

Low ambient cooling

To determine when to operate in low ambient mode, the UCB has an outdoor air temperature sensor (OAT) with a low ambient setpoint at 45°F (default). When the OAT sensor senses a temperature below the low ambient setpoint and the thermostat is calling for cooling, the UCB operates in the low ambient mode.

Low ambient mode operates the compressors in the following manner: 10 minutes on, 5 minutes off. The indoor blower is operated throughout the cycle. The 5-minute off period is necessary to defrost the indoor coil.

Low ambient mode always begins with compressor operation. Compressor minimum run time may extend the minutes of compressor operation. The off cycle begins immediately following the elapse of the minimum run time.

When operating in low ambient mode, an evaporator low limit sensor (EC1, 2) temperature below 26°F, the UCB de-energizes the associated compressor. If the call for cooling is still present at the end of the ASCD and the evaporator temperature sensor (EC1, 2) temperature is above 26°F, the unit resumes operation.

Safety controls

The unit control board monitors the following inputs for each cooling system:

1. An evaporator low limit sensor (EC1, 2) to protect against low evaporator temperatures due to a low airflow or a low return air temperature, set at 26°F. The sensor is located on the suction line at the evaporator coil.
2. A high-pressure switch to protect against excessive discharge pressures due to a blocked condenser coil or a condenser motor failure. The switch opens at 625 ± 25 psig and resets 500 ± 25 psig.
3. A low-pressure switch to protect against loss of refrigerant charge. The switch opens at 50 ± 5 psig and resets at 71 ± 5 psig.

The above pressure switches are hard-soldered to the unit. The refrigeration systems are independently monitored and controlled. On any fault, only the associated system is affected by any safety/preventive action. The other refrigerant system continues in operation unless it is affected by the fault as well.

The unit control board monitors the temperature limit switch of electric heat units and the temperature limit switch and the gas valve of gas furnace units.

Compressor protection

In addition to the external pressure switches, the compressors also have inherent (internal) protection. If there is an abnormal temperature rise in a compressor, the protector opens to shut down the compressor. The UCB incorporates features to minimize compressor wear and damage. An anti-short cycle delay (ASCD) is used to prevent operation of a compressor too soon after its previous run. Additionally, a minimum run time is imposed any time a compressor is energized.

The ASCD is initiated on unit start-up and on any compressor reset or lock-out.

Reset

Remove the call for cooling by raising thermostat setting higher than the conditioned space temperature.

Reheat sequence of operation

Normal occupied operation mode

If the return humidity is greater than or equal to the hot gas reheat humidity setpoint, and no demand for cooling, C1 output energizes and the AUX-HGR output energizes.

If there is a demand for one stage of cooling and the return humidity is greater than or equal to the hot gas reheat humidity setpoint, C1 output energizes but the AUX-HGR output de-energizes.

Any additional cooling demands energize compressor outputs, but do not change the status of the AUX-HGR output.

When the return humidity falls to 3% or more below the setpoint, the C1 and AUX-HGR outputs de-energize.

Note: If HGR enabled for unoccupied operation is enabled, during unoccupied mode the control works the same as described above, except it uses the HGR unoccupied humidity setpoint instead.

Alternate mode

If the return humidity is greater than or equal to the hot gas reheat humidity setpoint, and there is no demand for cooling, C1 and AUX-HGR outputs energize, and C2 energizes.

If there is a demand for one stage of cooling and the return humidity is greater than or equal to the hot gas reheat humidity setpoint, C1 and AUX-HGR outputs energize, and C2 energizes.

If there is a demand for both first and second cooling stages and the return humidity is greater than or equal to the hot gas reheat humidity setpoint, C1 and C2 outputs energize and AUX-HGR de-energizes.

Any additional cooling demands energize compressor outputs, but do not change the status of the AUX-HGR output.

Auxiliary mode enabled

When operating reheat in the Alternate mode, if the space dry-bulb temperature condition is satisfied while a dehumidification demand is active, the UCB toggles the mode of reheat from Alternate to Normal until a demand for cooling is present again. When a call for cooling is present, the UCB returns the Reheat mode back to Alternate.

Table 20: ZT180-210 3 stage dehumidification sequence in normal and alternate mode

Request	Normal mode				Alternate mode			
	HGR	C1	C2	C3	HGR	C1	C2	C3
Dehumidification	On	On	Off	Off	On	On	On	Off
One stage of cooling (Y1)	Off	On	Off	Off	On	On	On	Off
Two stages of cooling (Y2)	Off	On	On	Off	Off	On	On	Off
Three stages of cooling (Y3)	Off	On	On	On	Off	On	On	On

Table 21: ZT240-276 4 stage dehumidification sequence in normal and alternate mode

Request	Normal mode					Alternate mode				
	HGR	C1	C2	C3	C4	HGR	C1	C2	C3	C4
Dehumidification	On	On	Off	Off	Off	On	On	On	Off	Off
One stage of cooling (Y1)	Off	On	Off	Off	Off	On	On	On	Off	Off
Two stages of cooling (Y2)	Off	On	On	Off	Off	Off	On	On	Off	Off
Three stages of cooling (Y3)	Off	On	On	On	Off	Off	On	On	On	Off
Four stages of cooling (Y4)	Off	On	On	On	On	Off	On	On	On	On

Electric heating sequence of operations

The following sequence describes the operation of the electric heat section.

CAUTION

For units with VFD and electric heat, the speed of the indoor blower motor continues to be controlled by duct static pressure through the Smart Equipment™ control board.

If there are VAV boxes present in the duct system, the boxes must be driven to the full-open position using a customer-supplied power source to assure adequate airflow across the heating elements.

Single-stage heating

This applies only to the 18 KW heater, all other heaters must use a two-stage thermostat.

- a. When there is a call for heat by the thermostat, the heater contactor (6M) is energized. After completing the specified fan on delay for heating, the UCB energizes the blower motor.
- b. The thermostat cycles the electric heat to satisfy the heating requirements of the conditioned space.

Two-stage heating

This applies to all heaters except the 18 KW heater.

- a. When there is a call for first-stage heat by the thermostat, the heater contactor (6M) (6M and 7M on 72 KW, 240V) is energized. After completing the specified fan on delay for heating, the UCB energizes the blower motor.

If the second stage of heat is required, heater contactor (7M) is energized. Note that on the 54 KW, 240V heater, heater contactors (7M & 8M) are energized and on the 72 KW, 240V heater, heater contactors (8M & 9M) are energized. After completing the specified fan on delay for heating, the UCB energizes the blower motor.

- b. The thermostat cycles the electric heat to satisfy the heating requirements of the conditioned space.

Note: All 240 and 480V heaters are provided with manual reset backup protection limits. These de-energize the heaters if the primary limit fails to open or the contactors fail to open in a failure mode.

Electric heat operation errors

Temperature limit

If the UCB senses zero volts from the high temperature limit, the indoor blower motor is immediately energized.

This limit is monitored regardless of unit operation status, that is, the limit is monitored at all times.

If the temperature limit opens three times within one hour, it locks on the indoor blower motor.

Safety controls

The UCB monitors the temperature limit switch of electric heat units.

The control circuit includes the following safety controls:

Temperature limit switch (TLS)

1. Temperature limit switch (TLS 1, 2).

This control is located inside the heater compartment and is set to open at the temperature indicated in Table 22. It resets automatically. The limit switch operates when a high temperature condition, caused by inadequate supply air flow occurs, this shuts down the heater and energizing the blower.

2. Temperature limit switch (TLS 3, 4, 5 and 6).

This control is located inside the heater compartment and is set to open at the temperature indicated in the Table 22. It is a manual reset limit. These limit switches de-energize the heaters if the primary limit fails to open or the contactors fail to open in a failure mode.

Table 22: Limit control setting

Unit (tons)	Voltage	Heater Kw	Temperature, limit switch 1, 2 opens, °F	Temperature, limit switch 3, 4, 5, 6 opens, °F
15, 17.5, 20, and 23	240	18	140	200
		36	140	200
		54	140	200
		72	140	200
15, 17.5, 20, and 23	460	18	120	170
		36	120	170
		54	120	170
		72	120	170

Reset

Remove the call for heating by lowering the thermostat setting lower than the conditioned space temperature.

Electric heat anticipator setpoints

The anticipator setpoint must be correct. Too high of a setting results in longer heat cycles and a greater temperature swing in the conditioned space. Reducing the value below the correct setpoint gives shorter ON cycles and may result in the lowering of the temperature within the conditioned space. See Table 23 for the required electric heat anticipator setting.

Table 23: Electric heat anticipator setpoint

Heater Kw	Voltage	Setting, amps	
		Th1	Th2
18	208/230-3-60	0.29	-
36		0.29	0.29
54		0.29	0.58
72		0.29	0.58

Table 23: Electric heat anticipator setpoint

Heater Kw	Voltage	Setting, amps	
		Th1	Th2
18	460-3-60	0.29	-
36		0.29	0.29
54		0.29	0.29
72		0.29	0.29

Gas heating sequence of operations

The following sequence describes the operation of the gas heat section.

⚠ CAUTION

For units with VFD and gas heat, the speed of the indoor blower motor continues to be controlled by duct static pressure via the UCB.

If there are VAV boxes present in the duct system, the boxes must be driven to the full-open position using a customer-supplied power source to assure adequate airflow across the heat exchanger tubes.

When the thermostat calls for the first stage of heating, the low-voltage control circuit from R to W1 is completed, through the UCB. The heat relay RW1 is energized. The RW1-2 contacts close, energizing the draft motor control. The draft motor control contacts close and start the draft motor. As the speed of the draft motor reaches approximately 2500 RPM, the centrifugal switch contact, located on the end of the draft motor shaft, closes to power the first stage ignition module IC1, through the RW1-1 contacts.

The ignition module IC1 initiates a 15 sec. pre-purge, then starts the first stage igniter sparking and opens the redundant valve located inside the first stage main gas valve GV1 to allow a flow of gas to only the first stage carryover tube. Only after the pilot flame is ignited and the presence of a pilot flame is detected at the IC1 by a signal sent back through the flame sensor is sparking terminated and the first stage main gas valve opened.

Gas flows into each of the main burners and is ignited from the carryover tube flame.

After completing the specified fan on delay for heating, the UCB energizes the blower motor.

If IC1 fails to detect a pilot flame, it continues to try for a maximum of 85 seconds to ignite the pilot tube. If the pilot flame is not detected, then IC1 locks out first stage furnace operation for five minutes or until 24V power is removed from the module either at the unit or by resetting the room thermostat.

When the thermostat calls for the second stage of heating, the low-voltage control circuit from R to W2 is completed, through the UCB. Heat relay RW2 is energized. The RW2-1 contact is closed energizing the second stage ignition module IC2. IC2 initiates a 15 sec. pre-purge, then starts the second stage igniter sparking and opens the redundant valve located inside

the second stage main gas valve GV2 to allow a flow of gas to the second stage carryover tube. Only after the pilot flame is ignited and the presence of a pilot flame is detected at IC2 by a signal sent back through the flame sensor is sparking terminated and the main gas valve opened.

Gas flows into each of the second stage main burners and is ignited from the carryover tube flame.

If IC2 fails to detect a pilot flame, it continues to try for a maximum of 85 seconds to ignite the pilot tube. If the pilot flame is not detected, then IC2 locks out first stage furnace operation for five minutes or until 24V power is removed from the module either at the unit or by resetting the room thermostat.

Note: That the second stage furnace can operate even if first stage is locked out.

When the thermostat satisfies de-energizing the RW2 and RW1, thus opening all gas valves. The blower motor continues to run after the furnace is shut down until the specified fan off delay for heating is satisfied. The UCB de-energizes the blower motor.

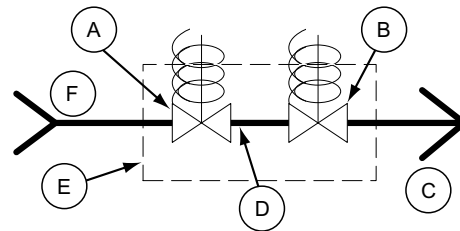

Item	Description	Item	Description
A	Redundant valve	D	To pilot burner
B	Main valve	E	Gas valve
C	To main burner	F	Gas main

Figure 20: Gas valve piping

When the thermostat calls for the first stage of heating, the low-voltage control circuit from R to W1 is completed. A call for heat passes through the UCB to the ignition control board (ICB). The UCB monitors the W1 call and acts upon any call for heat. When voltage is sensed at W1, the UCB initiates the fan on delay for heating, energizing the indoor blower after the specified delay has elapsed.

When the thermostat is satisfied, heating calls are ceased. The GV is immediately de-energized. The blower is de-energized after the fan off delay for heating has elapsed. The draft motor performs a 25-second post purge.

Gas heating operation errors

Temperature limit

If the UCB senses zero volts from the high temperature limit, the indoor blower motor is immediately energized. When the UCB again senses 24 volts from the temperature limit, the draft motor performs a 25-second post-purge and the indoor blower is de-energized following the elapse of the fan off delay for heating.

This limit is monitored regardless of unit operation status, that is, this limit is monitored at all times.

If the temperature limit opens three times within one hour, it locks on the indoor blower motor.

Gas valve

The UCB continuously monitors the GV. Any time the UCB senses voltage at the GV without a call for heat for a continuous five-minute period, the UCB locks on the indoor blower. When voltage is no longer sensed at the GV, the UCB de-energizes the indoor blower following the elapse of the fan off delay for heating.

If voltage is sensed at the GV for at least 15 seconds during the fan on delay for heating and GV voltage or W1 is lost, the indoor blower is forced on for the length of the fan off delay for heating.

Safety controls

The UCB monitors the temperature limit switch of gas heat units.

The control circuit includes the following safety controls.

Limit switch

The limit switch (LS) is located inside the gas heat compartment and is set to open at the temperature indicated in Table 24. It resets automatically. The limit switch operates when a high temperature condition, caused by inadequate supply air flow occurs. This shuts down the heater and energizes the blower.

Centrifugal switch

If the draft motor fails, the centrifugal switch attached to the shaft of the motor prevents the ignition controls and gas valves from being energized.

Redundant gas valve

There are two separate gas valves in the furnace. Each valve contains a main and a redundant valve. The redundant valves are located upstream of the main gas valves. If either or both of the main gas valves fail in the open position, the redundant valves serve as back-ups and shut off the flow of gas.

Flame sensor rod / 100% ignition control lock-out

The flame rods and controls are located according to Figure 22. If an ignition control fails to detect a signal from the flame sensor indicating the pilot flame is properly ignited, then the main gas valve does not open. It continues to try and ignite the pilot for a maximum of 85 seconds, then if the pilot flame is not detected, the ignition control locks out furnace operation until 24V power is removed from the module either at the unit or by resetting the room thermostat.

Rollout switch

This roll-out switch (ROS) is located above the main burners in the control compartment. In the event of a sustained main burner rollout, the switch shuts off and locks out both ignition controls closing both gas valves. The ignition controls lock out furnace operation until 24V power is removed from the controls either at the unit or by resetting the room thermostat.

Auxiliary limit switch

The auxiliary limit switch (AUX) is located inside the heat exchanger compartment and is set to open at 190°F. It is a manual reset switch. If AUX trips, then the primary limit has not functioned correctly. Replace the primary limit.

Table 24: Gas heat limit control setting

Unit (tons)	Capacity, MBH		Limit control opens °F
	Input	Output	
15, 17.5, 20 & 23	300	240	195
15, 17.5, 20 & 23	400	320	195

The ICB monitors the pressure and rollout switches of gas heat units.

The control circuit includes the following safety controls:

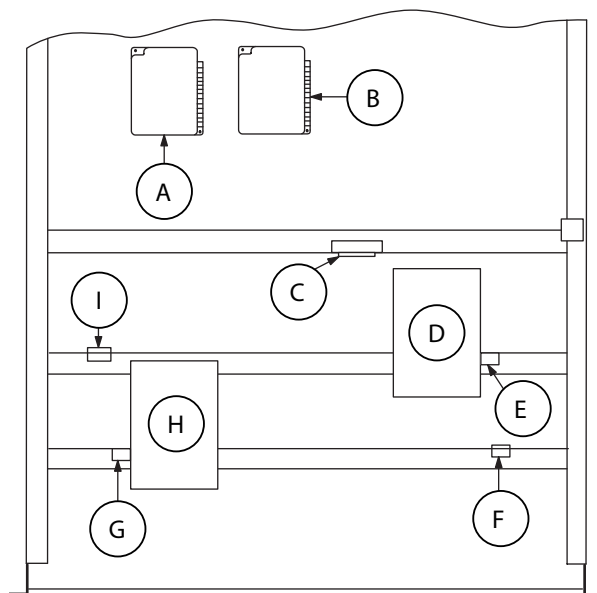

Item	Description	Item	Description
A	Ignitor control 1	F	Sensor 2
B	Ignitor control 2	G	Ignitor 2
C	Rollout switch	H	GV2 gas valve
D	GV1 gas valve	I	Sensor 1
E	Ignitor 1		

Figure 21: Burner compartment - gas valve and controls

Resets

Remove the call for heating by lowering the thermostat setting lower than the conditioned space temperature.

Gas heat anticipator setpoints

It is important that the anticipator setpoint be correct. Too high of a setting results in longer heat cycles and a greater temperature swing in the conditioned space. Reducing the value below the correct setpoint gives shorter ON cycles and may result in the lowering of the temperature within the conditioned space. See Table 25 for the required gas heat anticipator setting.

Table 25: Gas heat anticipator setpoints

Gas valve	Anticipator setpoint	
	1st stage	2nd stage
Honeywell VR8440	0.30 amp	0.11 amp
White-Rodgers 36C68		

Cooling start-up

Pre-start checklist

When the installation is complete, perform the following checks:

1. Check the electrical supply voltage being supplied. Verify that it is the same as the voltage listed on the unit nameplate.
2. Set the room thermostat to the off position.
3. Turn on electrical power to the unit.
4. Set the room thermostat fan switch to on.
5. Check the indoor blower rotation.
 - If the blower rotation is in the wrong direction, see *Phasing* on page 34.
 Check the blower drive belt tension.
6. Check the unit supply air (CFM).
7. Measure the evaporator fan motor's amp draw.
8. Set the room thermostat fan switch to off.
9. Turn off electrical power to the unit.

Operating the unit

1. Turn on electrical power to the unit.
2. Set the room thermostat setting lower than the room temperature.

First stage compressors energize after the built-in time delay of five minutes.

The second stage of the thermostat energizes the second stage compressor if needed.

Post-start checklist

1. Verify proper system pressures for both circuits.
2. Measure the temperature drop across the evaporator coil.
3. Measure the system amperage draw across all legs of 3 phase power wires.
4. Measure the condenser fan amperage draw.

Gas heat start-up

Pre-start checklist

Complete the following checks before you start the unit.

1. Check the type of gas being supplied. Verify that it is the same as the gas supply listed on the unit nameplate.

2. Verify that the vent and combustion hoods are properly installed.

Operating instructions

CAUTION

This furnace is equipped with an intermittent pilot and automatic re-ignition system. DO NOT attempt to manually light the pilot.

Lighting the main burners

1. Turn off electrical power to unit.
2. Turn the room thermostat to lowest setting.
3. Turn the gas valve knob or switch to the ON position. See Figure 24.
4. Turn on electrical power to unit.
5. Set room thermostat to the required temperature.

If the thermostat set temperature is above room temperature, pilot burner ignition occurs and, after an interval to prove pilot flame, the main burners ignite.

Post-start checklist

After the entire control circuit is energized and the heating section is operating, perform the following checks:

1. Check for gas leaks in the unit piping and the supply piping.

WARNING

Fire or explosion hazard
Failure to follow the safety warning exactly could result in serious injury, death, or property damage.
Never test for gas leaks with an open flame. Use a commercially available soap solution made specifically for the detection of leaks to check all connections. A fire or explosion may result causing property damage, personal injury or loss of life.

2. Check for correct manifold gas pressures. See *Checking gas heat input* on page 49.
3. Check the supply gas pressure. It must be within the limits shown on the rating nameplate.

Note: You must check supply pressure with all gas appliances in the building at full fire. The standby gas pressure must never exceed 13 in. or the operating pressure drop below 5.0 in for natural gas units. If gas pressure is outside these limits, contact the local gas utility or propane supplier for corrective action.

Shutting down the unit

1. Set the thermostat to the lowest temperature setting.

2. Turn off all electrical power to unit.
3. Open the gas heat access panel.
4. Turn the gas valve clockwise to the OFF position (See Figure 24).

Checking gas heat input

1. Turn off all other gas appliances connected to the gas meter.
2. With the furnace turned on, measure the time needed for one revolution of the hand on the smallest dial on the meter. A typical gas meter usually has a 1/2 or a 1 cubic foot test dial.
3. Using the number of seconds for each revolution and the size of the test dial increment, find the cubic feet of gas consumed per hour from Table 26.

If the actual input is not within 5% of the furnace rating (with allowance being made for the permissible range of the regulator setting), replace the orifice spuds with spuds of the proper size.

To find the BTU input, multiply the number of cubic feet of gas consumed per hour by the BTU content of the gas in your particular locality.

Note: The BTU content of gas varies widely from area to area, contact your gas company for this information.

Table 26: Gas rate cubic feet per hour

Seconds for one rev.	Size of test dial	
	1/2 cu. ft.	1 cu. ft.
4	450	900
6	300	600
8	228	450
10	180	360
12	150	300
14	129	257
16	113	225
18	100	200
20	90	180
22	82	164
24	75	150
26	69	138
28	64	129

Example calculation

- By actual measurement, it takes 13 seconds for the hand on the 1-cubic foot dial to make a revolution with just a 300,000 BTU/h furnace running.

- Read across to the column in the table above, headed 1 cubic foot. 278 cubic feet of gas per hour are consumed by the furnace at that rate.
- Multiply 278 x 1050. The BTU rating of the gas obtained from the local gas company.
- The result is 292,425 BTU/h, which is close to the 300,000 BTU/h rating of the furnace.

Adjusting the manifold gas pressure

Small adjustments to the high-fire gas flow may be made by turning the pressure regulator adjusting screw on the automatic gas valve.

1. Remove the cap on the regulator. It is located next to the push-on electrical terminals.
2. To decrease the gas pressure, turn the adjusting screw counterclockwise.

To increase the gas pressure, turn the adjusting screw clockwise.

Note: The correct manifold pressure for these furnaces is 3.65 IWG ± 0.3.

Adjusting the temperature rise

The temperature rise is the difference of temperature between the return air and the heated air from the furnace. It must lie within the range shown on the CSA rating plate and the data in Table 11.

After the temperature rise is determined, the CFM can be calculated as follows:

$$\text{CFM} = \text{Btu Input} \cdot \frac{0.8}{(1.08 \cdot \Delta^{\circ}\text{F})}$$

After about 20 minutes of operation, determine the furnace temperature rise.

- Take readings of both the return air and the heated air in the ducts (about 6 feet from the furnace) where they are not be affected by radiant heat.
- Increase the blower CFM to decrease the temperature rise
- Decrease the blower CFM to increase the rise

See *Supply air drive adjustment* on page 41.

Note: Each gas heat exchanger size has a minimum allowable CFM. Below this CFM, the limit opens.

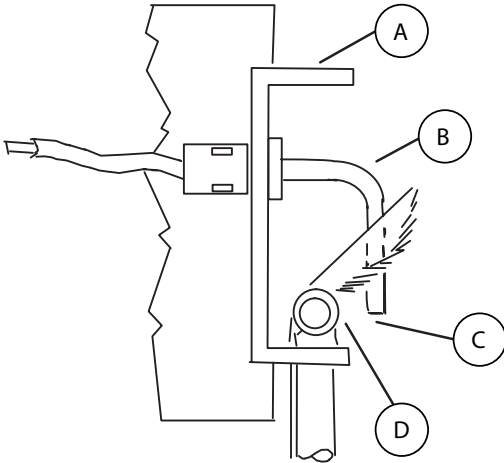

Item	Description	Item	Description
A	Burner assembly bracket	C	1/8 in. gap between carry-over tube and the flame sensor bulb
B	Flame sensor bulb	D	Carry-over tube

Figure 22: Pilot flame adjustment

Pilot checkout

The pilot flame must envelope the end of the flame sensor. To adjust pilot flame, complete the following steps.

1. Remove pilot adjustment cover screw.
2. Increase or decrease the clearance for air to the required level.
3. Replace the cover screw after adjustment to prevent possible gas leakage.
4. Put the system into operation and observe a complete cycle to be sure all controls function properly.

Burner instructions

WARNING

Before you check or change burners, pilot, or orifices, close the main manual shut-off valve and turn off all electrical power to the unit.

1. Remove the screws that hold each end of the manifold to the burner supports.

2. Open the union fitting in the gas supply line just upstream of the unit gas valve and downstream from the main manual shut-off valve.
3. Remove the gas piping closure panel.
4. Disconnect the wiring to the gas valves and spark ignitors.
5. Remove the manifold-burner gas valve assembly by lifting up and pulling back.

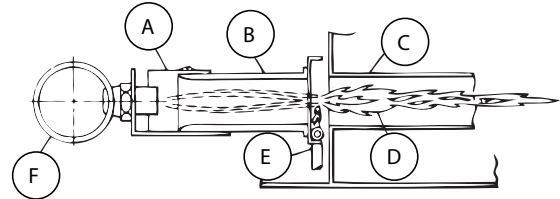

Item	Description	Item	Description
A	Adjustable shutter	D	Burner flame (blue only)
B	Burner	E	Pilot tube
C	Heat tube exchanger	F	Gas supply line

Figure 23: Typical flame

The burners are now accessible for service.

Reverse the above procedure to replace the assemblies. Make sure that burners are level and seated at the rear of the heat exchanger.

Burner air shutter adjustment

Adjust the burner shutters so that no yellow flame is observed in the heat exchanger tubes.

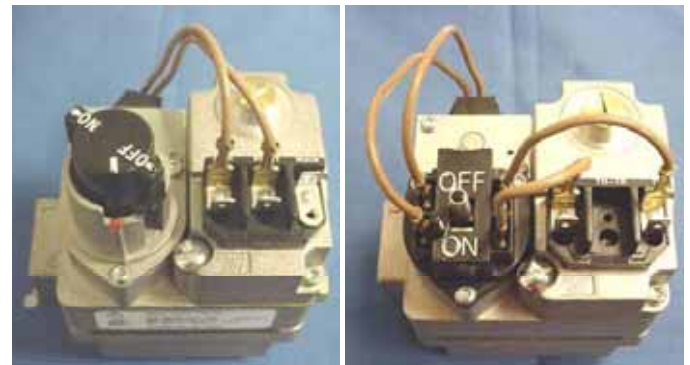

Figure 24: Typical gas valve

Charging the unit

Note: You must charge the unit according to the weight of refrigerant listed on the unit data tag.

Table 27: ZT180 charging table - system 1

Air flow Indoor Db/Wb	Outdoor DB	Suction pressure	Suction temp.	Discharge pressure	Liquid temp.	Delta T Db
300 CFM/ton 80/62	75	121	55	273	74	30
	85	124	55	314	85	29
	95	126	54	360	95	28
300 CFM/ton 80/67	75	127	67	279	75	25
	85	134	64	321	85	24
	95	137	61	365	95	23
300 CFM/ton 80/72	75	132	73	284	75	19
	85	141	72	329	85	19
	95	147	70	376	95	18
300 CFM/ton 75/62	75	120	55	274	75	25
	85	124	54	316	85	24
	95	126	54	361	95	23
400 CFM/ton 80/62	75	124	61	276	75	25
	85	128	57	319	85	24
	95	132	58	365	95	24
400 CFM/ton 80/67	75	131	72	282	75	21
	85	137	70	324	85	20
	95	141	66	370	96	20
400 CFM/ton 80/72	75	133	74	284	74	15
	85	141	74	328	84	15
	95	149	73	379	96	15
400 CFM/ton 75/62	75	125	62	277	75	21
	85	129	59	318	85	21
	95	131	57	364	95	20

Table 28: ZT180 charging table - system 2

Air flow Indoor Db/Wb	Outdoor DB	Suction pressure	Suction temp.	Discharge pressure	Liquid temp.	Delta T Db
300 CFM/ton 80/62	75	117	57	268	75	30
	85	123	55	313	86	29
	95	126	53	359	97	28
300 CFM/ton 80/67	75	125	67	275	75	25
	85	131	64	317	86	24
	95	137	62	365	97	23
300 CFM/ton 80/72	75	130	73	280	75	19
	85	139	71	326	86	19
	95	146	70	374	97	18
300 CFM/ton 75/62	75	118	55	272	76	25
	85	122	54	316	87	24
	95	126	53	363	98	23
400 CFM/ton 80/62	75	121	61	272	75	25
	85	126	56	317	86	24
	95	133	58	365	98	24
400 CFM/ton 80/67	75	128	72	277	75	21
	85	136	70	321	86	20
	95	142	67	370	97	20
400 CFM/ton 80/72	75	131	74	279	75	15
	85	140	74	324	85	15
	95	149	73	377	97	15
400 CFM/ton 75/62	75	123	63	274	76	21
	85	128	59	317	87	21
	95	132	58	365	98	20

Table 29: ZT210 charging table - system 1

Air flow Indoor Db/Wb	Outdoor DB	Suction pressure	Suction temp.	Discharge pressure	Liquid temp.	Delta T Db
300 CFM/ton 80/62	75	119	51	277	73	29
	85	123	53	323	84	28
	95	126	55	369	94	27
300 CFM/ton 80/67	75	131	58	289	75	25
	85	133	59	328	84	24
	95	137	61	376	95	23
300 CFM/ton 80/72	75	142	64	290	74	20
	85	143	65	322	82	19
	95	147	66	372	93	18
300 CFM/ton 75/62	75	121	52	282	75	24
	85	124	54	326	85	24
	95	127	55	374	95	23
400 CFM/ton 80/62	75	126	54	279	73	24
	85	129	55	329	85	23
	95	133	57	376	95	23
400 CFM/ton 80/67	75	140	62	292	76	21
	85	141	63	333	85	20
	95	143	64	381	95	19
400 CFM/ton 80/72	75	150	68	297	75	16
	85	153	69	342	86	15
	95	156	70	390	96	14
400 CFM/ton 75/62	75	127	55	279	73	21
	85	130	56	321	83	20
	95	133	57	367	93	19

Table 30: ZT210 charging table - system 2

Air flow Indoor Db/Wb	Outdoor DB	Suction pressure	Suction temp.	Discharge pressure	Liquid temp.	Delta T Db
300 CFM/ton 80/62	75	119	52	285	75	29
	85	124	54	322	84	28
	95	126	55	371	94	27
300 CFM/ton 80/67	75	130	59	289	75	25
	85	134	59	328	84	24
	95	139	60	377	95	23
300 CFM/ton 80/72	75	140	65	297	76	20
	85	143	66	338	85	19
	95	148	66	391	96	18
300 CFM/ton 75/62	75	120	53	283	75	24
	85	124	54	329	85	24
	95	128	55	378	95	23
400 CFM/ton 80/62	75	127	56	287	75	24
	85	129	56	330	84	23
	95	134	58	377	95	23
400 CFM/ton 80/67	75	138	64	289	74	21
	85	141	64	338	86	20
	95	144	64	389	96	19
400 CFM/ton 80/72	75	146	70	293	74	16
	85	151	70	340	85	15
	95	155	71	390	95	14
400 CFM/ton 75/62	75	127	56	287	75	21
	85	131	57	333	86	20
	95	134	57	381	96	19

Table 31: ZT240 charging table - system 1

Air flow Indoor Db/Wb	Outdoor DB	Suction pressure	Suction temp.	Discharge pressure	Liquid temp.	Delta T Db
300 CFM/ton 80/62	75	117	52	301	84	30
	85	119	53	342	91	30
	95	122	54	389	99	29
300 CFM/ton 80/67	75	127	58	307	87	26
	85	131	59	351	94	25
	95	134	60	398	102	24
300 CFM/ton 80/72	75	134	64	314	91	20
	85	141	64	358	97	20
	95	145	65	404	104	19
300 CFM/ton 75/62	75	117	52	300	84	26
	85	120	53	345	92	25
	95	123	54	391	99	24
400 CFM/ton 80/62	75	123	56	305	85	26
	85	126	55	349	93	25
	95	129	56	395	100	24
400 CFM/ton 80/67	75	132	62	312	90	21
	85	138	61	356	96	20
	95	141	62	403	103	20
400 CFM/ton 80/72	75	137	68	317	92	16
	85	145	67	363	98	16
	95	151	69	412	106	15
400 CFM/ton 75/62	75	124	56	306	86	22
	85	127	57	348	93	21
	95	129	57	395	101	20

Table 32: ZT240 charging table - system 2

Air flow Indoor Db/Wb	Outdoor DB	Suction pressure	Suction temp.	Discharge pressure	Liquid temp.	Delta T Db
300 CFM/ton 80/62	75	119	52	295	80	30
	85	121	53	337	89	30
	95	124	54	386	100	29
300 CFM/ton 80/67	75	130	60	301	80	26
	85	133	60	345	91	25
	95	136	61	394	101	24
300 CFM/ton 80/72	75	142	70	307	80	20
	85	144	68	351	91	20
	95	147	68	399	102	19
300 CFM/ton 75/62	75	119	52	294	79	26
	85	122	53	340	90	25
	95	124	54	387	100	24
400 CFM/ton 80/62	75	126	57	299	80	26
	85	129	56	344	91	25
	95	131	57	392	101	24
400 CFM/ton 80/67	75	138	67	306	80	21
	85	141	64	350	92	20
	95	143	64	398	102	20
400 CFM/ton 80/72	75	149	72	313	80	16
	85	152	72	357	91	16
	95	155	71	406	102	15
400 CFM/ton 75/62	75	126	58	300	80	22
	85	129	58	343	90	21
	95	132	57	391	101	20

Table 33: ZT276 charging table - system 1

Air flow Indoor Db/Wb	Outdoor DB	Suction pressure	Suction temp.	Discharge pressure	Liquid temp.	Delta T Db
300 CFM/ton 80/62	75	129	55	289	80	25
	85	128	55	335	90	26
	95	127	54	380	99	27
300 CFM/ton 80/67	75	129	55	290	80	25
	85	132	56	337	90	24
	95	135	58	383	100	23
300 CFM/ton 80/72	75	129	56	292	80	25
	85	136	58	339	91	22
	95	143	61	386	101	20
300 CFM/ton 75/62	75	124	52	287	79	23
	85	125	53	334	89	23
	95	126	53	380	99	23
400 CFM/ton 80/62	75	133	57	293	81	22
	85	134	57	339	91	22
	95	136	58	386	101	22
400 CFM/ton 80/67	75	134	57	294	81	21
	85	137	59	341	91	21
	95	141	60	388	101	20
400 CFM/ton 80/72	75	135	58	296	81	21
	85	140	60	343	91	19
	95	145	62	391	101	18
400 CFM/ton 75/62	75	128	54	290	80	19
	85	130	55	338	90	19
	95	132	56	385	100	19

Table 34: ZT276 charging table - system 2

Air flow Indoor Db/Wb	Outdoor DB	Suction pressure	Suction temp.	Discharge pressure	Liquid temp.	Delta T Db
300 CFM/ton 80/62	75	129	56	291	79	25
	85	129	56	336	89	26
	95	129	56	382	100	27
300 CFM/ton 80/67	75	129	56	292	80	25
	85	133	57	339	90	24
	95	136	59	386	100	23
300 CFM/ton 80/72	75	129	56	293	80	25
	85	136	59	341	90	22
	95	144	62	389	101	20
300 CFM/ton 75/62	75	124	53	288	79	23
	85	125	54	335	89	23
	95	127	55	382	99	23
400 CFM/ton 80/62	75	134	57	293	80	22
	85	136	59	340	90	22
	95	137	60	386	100	22
400 CFM/ton 80/67	75	135	58	295	80	21
	85	138	60	342	90	21
	95	142	61	389	101	20
400 CFM/ton 80/72	75	136	58	296	80	21
	85	141	61	344	91	19
	95	146	63	391	101	18
400 CFM/ton 75/62	75	129	55	291	79	19
	85	131	56	338	90	19
	95	134	58	385	100	19

Smart Equipment™ unit control board

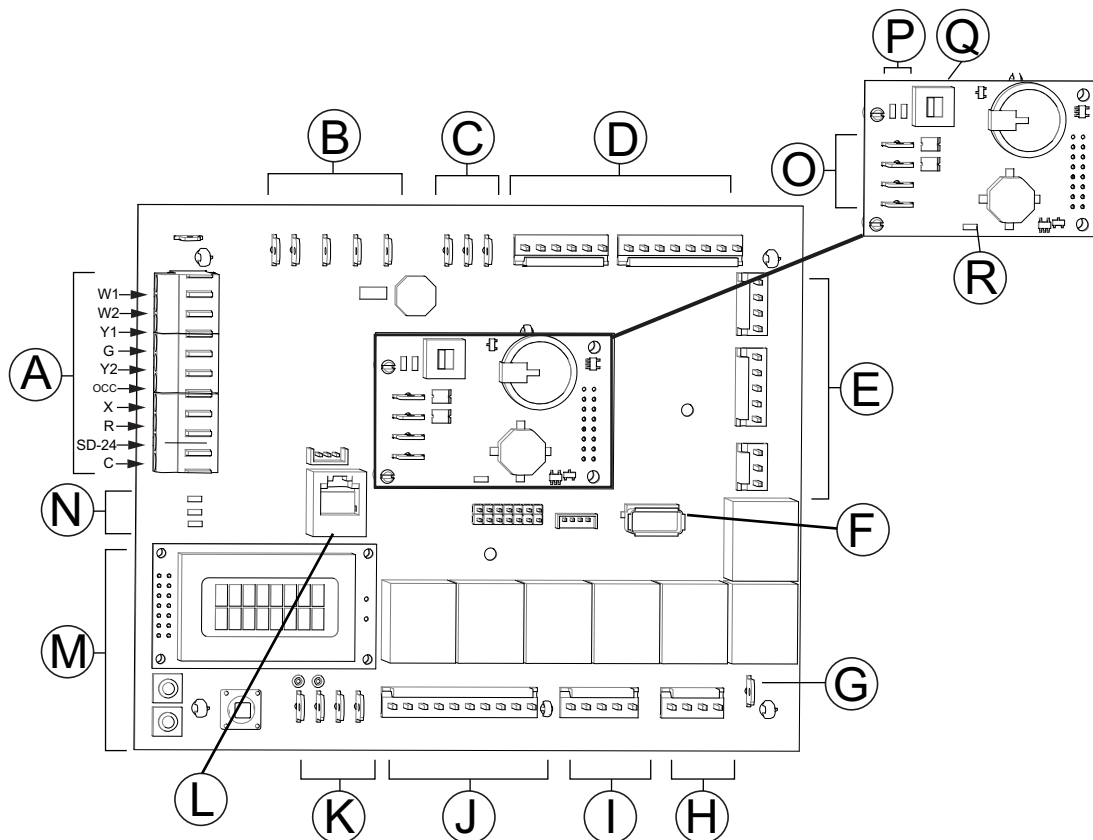

Figure 25: Smart Equipment™ unit control board

The following tables describe the details of the Smart Equipment™ UCB, see Figure 25 for the connection locations.

Smart Equipment™ UCB - thermostat connection strip

Location	Label	Description	Function and comments
A	W1	1st stage heating request, 24 VAC input switched from R	Not effective for cooling-only units
	W2	2nd stage heating request, 24 VAC input switched from R	Not effective for cooling-only units or units with single-stage heat sections
	Y1	1st stage cooling request, 24 VAC input switched from R	
	Y2	2nd stage cooling request, 24 VAC input switched from R	Visible in the display menu when the #ClgStgs parameter is set for 2 or more, also effective for economizer free cooling supply air temperature reset when the #ClgStgs parameter is set for 1 or more
	G	Continuous indoor blower request, 24 VAC input switched from R	
	OCC	Occupancy request, 24 VAC input switched from R	Must have the OccMode parameter set for External to be effective
	X	Hard lockout indicator, 24 volt output to a light thermostat LED	
	R	24 VAC hot for thermostat switching and power	If field-added external accessories for unit shutdown are used, 24 VAC hot return from smoke detector, condensate overflow and/or user shutdown relay switching in series
	SD-24	If field-added external accessories for unit shutdown are used, 24 VAC hot out for smoke detector, condensate overflow and/or user shutdown relay switching in series	Unit wiring harness jumper plug for factory shutdown accessories must be removed if the switching of field-added external accessories for unit shutdown are wired between thermostat connection strip SD-24 and R
	C	24 VAC common for thermostat power	

Smart Equipment™ UCB - limit, 24 VAC power, and shutdown connections

Location	Label	Description	Function and comments
B	LIMIT	Monitored 24 VAC input through heat section limit switch(es)	If voltage is absent, indicating the heat section is over-temperature, the UCB will bring on the indoor blower
	C	24 VAC, 75 VA transformer Common referenced to cabinet ground	Connects through circuit traces to thermostat connection strip C and indoor blower VFD pin C
	24V	24 VAC, 75 VA transformer hot	Powers the UCB microprocessor, connects through circuit trace to the SD 24 terminal
	SD 24	24 VAC hot out for factory accessory smoke detector, condensate overflow and/or user shutdown relay switching in series	Connects through circuit trace to thermostat connection strip SD-24. A wiring harness jumper plug connecting SD 24 to SD R is in place if factory accessories for unit shutdown are not used - this jumper plug must be removed if the switching of field-added external accessories for unit shutdown are wired between thermostat connection strip SD-24 and R
	SD R	24 VAC hot return from factory accessory smoke detector, condensate overflow and user shutdown relay switching in series	Connects through circuit trace to the R terminal on the upper left of the board
	R	24 VAC hot for switched inputs to the UCB	Connects through circuit trace to the thermostat connection strip R terminal, right FAN OVR pin, right HPS1 pin, right HPS2 pin, lower DFS pin and lower APS pin

Smart Equipment™ UCB - space temperature sensor connections

Location	Label	Description	Function and comments
C	ST	Space Temperature sensor input from 10KΩ @ 77°F, Type III negative temperature coefficient thermistor	Positive of VDC circuit (3.625 VDC reading to COM with open circuit), effective if "Thermo- stat-only Control" parameter is set OFF, space sensor override momentary shorts ST to COM to initiate/terminate temporary occupancy
	COM	Common for ST and SSO inputs	Negative of VDC circuit for ST and SSO inputs
	SSO	Space Sensor Offset input from 0 to 20KΩ potentiometer	Positive of VDC circuit (3.625 VDC reading to COM with open circuit), 10KΩ/2.5 VDC is 0°F offset, 0Ω/0 VDC is maximum above offset and 20KΩ/3.4 VDC is maximum below offset from active space temperature setpoint

Smart Equipment™ UCB - temperature sensor connections

Location	Label	Description	Function and comments
D	SAT+	Supply Air Temperature sensor input from 10KΩ @ 77°F, Type III negative temperature coefficient thermistor	Input required for operation; 3.625 VDC reading SAT+ to SAT- with open circuit. Used in heat/cool staging cutouts, free cooling operation, demand ventilation operation, comfort ventilation operation, economizer loading operation, VAV cooling operation, hydronic heat operation.
	RAT+	Return Air Temperature sensor input from 10KΩ @ 77°F, Type III negative temperature coefficient thermistor	Input required for operation; 3.625 VDC reading RAT+ to RAT- with open circuit. Used in return air enthalpy calculation. Substitutes for space temperature if no other space temperature input is present.
	OAT+	Outside Air Temperature sensor input from 10KΩ @ 77°F, Type III negative temperature coefficient thermistor	Input required for operation but may be a communicated value; 3.625 VDC reading OAT+ to OAT- with open circuit. Used in heat/cool cutouts, low ambient cooling determination, dry bulb free cooling changeover, outside air enthalpy calculation, economizer loading operation, heat pump demand defrost calculation.
	CC1+	#1 refrigerant circuit Condenser Coil temperature sensor input from 10KΩ @ 77°F, Type III negative temperature coefficient thermistor	Input required for heat pump units, not required for A/C units; 3.625 VDC reading CC1+ to CC1- with open circuit. Used in heat pump demand defrost calculation.
	EC1+	#1 refrigerant circuit Evaporator Coil temperature sensor input from 10KΩ @ 77°F, Type III negative temperature coefficient thermistor	Input required for operation; 3.625 VDC reading EC1+ to EC1- with open circuit. Used in suction line temperature safety.

Smart Equipment™ UCB - temperature sensor connections (continued)

Location	Label	Description	Function and comments
D	CC2+	#2 refrigerant circuit Condenser Coil temperature sensor input from 10KΩ @ 77°F, Type III negative temperature coefficient thermistor	Input required for 2-compressor heat pump units, not required for 2-compressor A/C units, not active for 1-compressor units; 3.625 VDC reading CC2+ to CC2- with open circuit. Used in heat pump demand defrost calculation.
	EC2+	#2 refrigerant circuit Evaporator Coil temperature sensor input from 10KΩ @ 77°F, Type III negative temperature coefficient thermistor	Input required for operation of 2-compressor units, not active for 1-compressor units; 3.625 VDC reading EC2+ to EC2- with open circuit. Used in suction line temperature safety.

Smart Equipment™ UCB - pinned connections

Location	Label	Description	Function and comments
E	RAH+	Return Air Humidity input from 0-10 VDC @ 0-100% RH sensor	Input required for reheat units, optional in all other units, may be a communicated value. Used in return air enthalpy calculation, temperature/humidity setpoint reset, reheat operation.
	DCT PRS+	Supply Duct Pressure input from 0-5 VDC @ 0-5" w.c. sensor	Input required for variable air volume units. Used in VAV indoor blower operation.
	DFS (upper pin)	24 VAC hot return from Dirty Filter Switch	Optional input; switch closure for greater than 15 seconds during indoor blower operation initiates a notification alarm
	DFS (lower pin)	24 VAC hot out for Dirty Filter Switch	Connects through circuit trace to the R terminal
	APS (upper pin)	24 VAC hot return from Air Proving Switch	When this optional input is enabled: the air proving switch must close within 30 seconds of initiation of indoor blower operation and not open for greater than 10 seconds during indoor blower operation to allow heat/cool operation and prevent an "APS open" alarm; the air proving switch must open within 30 seconds of termination of indoor blower operation to prevent an "APS stuck closed" notification alarm
	APS (lower pin)	24 VAC hot out for Air Proving Switch	Connects through circuit trace to the R terminal
	C	Common for the VFD output	Negative of the VDC circuit for the VFD output
	VFD	2-10 VDC (0-100%) output for the indoor blower Variable Frequency Drive	Output is active with indoor blower operation. For CV units: this output provides stepped IntelliSpeed control of the indoor blower VFD based on fan-only, cooling stage and heating stage outputs. For VAV units: this output provides control of the indoor blower VFD based on supply duct static pressure input and setpoint.
VFDFLT	24 VAC hot input from the normally open VFD alarm contact	The VFD alarm contact switches from R within the unit wiring harness. 24 VAC input results in unit shutdown and a "VFD fault" alarm	

Smart Equipment™ UCB - USB connector

Location	Label	Description	Function and comments
F	J10	Type A female Universal Serial Bus connector	Used for backup, restoration, & copying of board parameters as well as board software updating through a flash drive
	J15	Factory wired SA Bus connector	

Smart Equipment™ UCB - 24 V terminal

Location	Label	Description	Function and comments
G	24V FOR OUTPUTS	24 VAC hot for H1, H2, CN-FAN, AUX HGR, FAN C1 and C2 output relay contact switching	Output relay circuitry is isolated from other UCB components and the 24 VAC hot source may be from a second transformer in the unit

Smart Equipment™ UCB - heat section connections

Location	Label	Description	Function and comments
H	H1	24 VAC hot output for heat section stage 1	Not effective for cooling-only units. Output if demand is present and permissions allow one stage or two stages of heat section operation
	H2	24 VAC hot output for heat section stage 2	Not effective for cooling-only units or units with single-stage heat sections. Output if demand is present and permissions allow two stages of heat section operation
	MV	24 VAC hot input confirming heat section operation	Sourced from gas valve in gas heat units or first stage heat contactor in electric heat units. Input within 5 minutes from initiation of H1 output initiates the "Heat On Fan Delay" timer, loss of input following the termination of H1 output initiates the "Heat On Fan Delay" timer, no input within 5 minutes from initiation of H1 output initiates an "Ignition Failure" alarm, input for longer than 5 minutes without H1 output initiates a "Gas Valve Mis-wire" alarm

Smart Equipment™ UCB - pin cooling and fan output

Location	Label	Description	Function and comments
I	CN-FAN	24 VAC hot output for the condenser fan contactor coil	Output with either C1 or C2 output; interrupted during defrost cycle for heat pump units
	AUX HGR	24 VAC hot output for hot gas reheat components	Effective only for reheat units, output with reheat operation
	FAN	24 VAC hot output for indoor blower contactor coil/ indoor blower VFD enable relay coil	Output with heat/cool operation, G input or schedule demand
	C1	24 VAC hot output for compressor 1	If demand is present and permissions allow compressor 1 operation; output with compressor cooling, comfort ventilation cooling, reheat or heat pump heating demands
	C2	24 VAC hot output for compressor 2	Not effective for one stage compressor UCBs. If demand is present and permissions allow compressor 2 operation; output with compressor cooling, comfort ventilation cooling or heat pump heating demands

Smart Equipment™ UCB - refrigerant circuit safety switch and indoor blower overload connections

Location	Label	Description	Function and comments
J	HPS1 (right pin)	24 VAC hot out for refrigerant circuit 1 High Pressure Switch	Connects through circuit trace to the R terminal
	HPS1 (left pin)	24 VAC hot return from refrigerant circuit 1 High Pressure Switch	Input is only considered if C1 output is needed; input must be present to allow C1 output. Three HPS1 trips in a two hour period cause a "High Pressure Switch 1 Lockout" and C1 output is then prevented until alarm reset. Connects through circuit trace to the right LPS1 pin.
	LPS1 (right pin)	24 VAC hot out for refrigerant circuit 1 Low Pressure Switch	Connects through circuit trace to the left HSP1 pin
	LPS1 (left pin)	24 VAC hot return from refrigerant circuit 1 Low Pressure Switch	Input is only considered after 30 seconds of C1 output; afterwards, input must be present to allow C1 output. Three LPS1 trips in a one hour period cause a "Low Pressure Switch 1 Lockout" and C1 output is then prevented until alarm reset.
	HPS2 (right pin)	24 VAC hot out for refrigerant circuit 2 High Pressure Switch	Not effective for one stage compressor UCBs. Connects through circuit trace to the R terminal
	HPS2 (left pin)	24 VAC hot return from refrigerant circuit 2 High Pressure Switch	Not effective for one stage compressor UCBs. Input is only considered if C2 output is needed; input must be present to allow C1 output. Three HPS2 trips in a two hour period cause a "High Pressure Switch 1 Lockout" and C2 output is then prevented until alarm reset. Connects through circuit trace to the right LPS2 pin.

Smart Equipment™ UCB - refrigerant circuit safety switch and indoor blower overload connections (continued)

Location	Label	Description	Function and comments
J	LPS2 (right pin)	24 VAC hot out for refrigerant circuit 2 Low Pressure Switch	Not effective for one stage compressor UCBs. Connects through circuit trace to the left HSP2 pin
	LPS2 (left pin)	24 VAC hot return from refrigerant circuit 2 Low Pressure Switch	Not effective for one stage compressor UCBs. Input is only considered after 30 seconds of C2 output; afterwards, input must be present to allow C2 output. Three LPS2 trips in a one hour period cause a "Low Pressure Switch 2 Lockout" and C2 output is then prevented until alarm reset.
	FAN OVR (right pin)	24 VAC hot out for indoor blower FAN Overload relay contact/motor protector switch	Connects through circuit trace to the R terminal
	FAN OVR (left pin)	24 VAC hot return from indoor blower FAN Overload relay contact/motor protector switch	Input is only considered if FAN output is needed; input must be present to allow FAN output and unit operation. One FAN OVR trip lasting longer than 5 minutes or three FAN OVR trips in a two hour period cause a "Fan Overload Lockout" and unit operation is then prevented until alarm reset.

Smart Equipment™ UCB - SA BUS¹ connections

Location	Label	Description	Function and comments
K	PWR	Power for SA ("Sensor-Actuator") BUS devices	Also incorporated in the J8 6-pin phone jack connector at the left-center of the board. Positive of the 15 VDC (reading to C) circuit for powering an optional netstat and/or Multi Touch gateway
	C	Common for SA BUS power and communication circuits	Also incorporated in the J8 6-pin phone jack connector at the left-center of the board. Negative of the SA BUS circuits
	-	Communication for SA BUS devices	Also incorporated in the J8 6-pin phone jack connector at the left-center of the board. Positive of the VDC (typically, a fluctuating 1.5 to 3.5 volts reading to C; at least 0.25 volts lower than +) SA BUS communication circuit to optional economizer board, 4-stage board, fault detection & diagnostics board, netstat and/or Multi Touch gateway
	+	Communication for SA BUS devices	Also incorporated in the J8 6-pin phone jack connector at the left-center of the board. Positive of the VDC (typically, a fluctuating 1.5 to 3.5 volts reading to C; at least 0.25 volts higher than -) SA BUS communication circuit to optional economizer board, 4-stage board, fault detection & diagnostics board, netstat and/or Multi Touch gateway
L	J8	6-pin phone jack connector	Incorporates the SA BUS terminals for convenience/alternate connection of SA BUS devices, primarily used for temporary service connection of the Multi Touch gateway

1. When wiring unit and other devices using the SA Bus and FC Bus, see Table 32.

Smart Equipment™ UCB - user interface

Location	Label	Description	Function and comments
M	Display	On-board, 2-line x 8-character back-lit display	On-board display, buttons and joystick allow access to UCB, economizer, 4-stage and FDD board parameters
	ENTER	Button for display menu acknowledgment and navigation	
	CANCEL	Button for display menu navigation and zeroing of active compressor ASCD timer	
	JOY	4-way Joystick for display menu navigation	

Smart Equipment™ UCB - LEDs

Location	Label	Description	Function and comments
N	POWER	Green UCB power indicator	Lit indicates 24 VAC is present at C and 24V terminals
	FAULT	Red hard lockout, networking error and firmware error indicator	1/2 second on/off flashing indicates one or more alarm is currently active, 1/10th second on/off flashing indicates a networking error (polarity, addressing, etc.) or a firmware error (likely correctable with re-loading from USB flash drive)
	SA BUS	Green UCB SA bus communication transmission indicator	Lit/flickering indicates UCB SA bus communication is currently active, off indicates the UCB is awaiting SA bus communication

Smart Equipment™ UCB - optional communication sub-board

Location	Label	Description	Function and comments
O ¹ Terminal FC BUS connections	FC+	FC ("Field Connected") BUS BACnet MSTP communication	Positive of the VDC (typically, a fluctuating 1.5 to 3.5 volts reading to COM; at least 0.25 volts higher than -) FC bus BACnet MSTP communication circuit
	FC-	FC ("Field Connected") BUS BACnet MSTP communication	Positive of the VDC (typically, a fluctuating 1.5 to 3.5 volts reading to COM; at least 0.25 volts lower than +) FC bus BACnet MSTP communication circuit
	COM	Common for the FC ("Field Connected") BUS BACnet MSTP communication circuit	Negative of the VDC FC bus BACnet MSTP communication circuit
	SHLD	Shield for the FC ("Field Connected") BUS BACnet MSTP communication circuit	Earth ground reference of the cable to prevent interference on the FC bus BACnet MSTP communication circuit
Q	EOL switch	End Of Line selector switch for the FC BUS BACnet MSTP communication circuit	ON selected only for the UCB that is the terminus of the FC bus BACnet MSTP communication cable to prevent signal "bounce-back"
P	EOL	Green End Of Line indicator	Lit indicates the EOL switch is selected ON
	FC BUS	Green FC bus communication transmission indicator	Lit/flickering indicates outgoing UCB FC bus communication is currently active, off indicates the UCB is awaiting incoming FC bus communication
R	ISO PWR	Green communication board Isolated Power indicator	Lit indicates the UCB is supplying power to the communication sub-board

Four-stage board

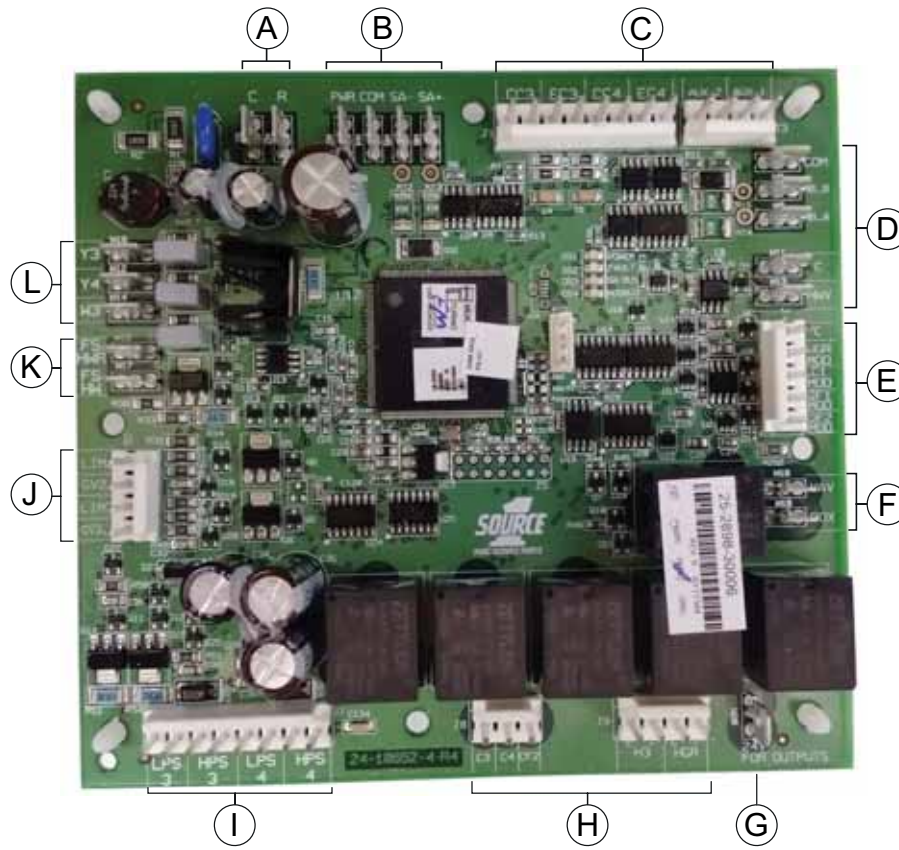

Figure 26: Four-stage board

The following tables describe the details of the four-stage board, see Figure 26 for the connection locations.

Four-stage board - power and communication terminals

Location	Terminal	Description	Function and comments
A	C	24VAC common for 4-stage board power	
	R	24VAC hot for 4-stage board power	
B	PWR	Sensor Actuator (SA) Bus Power for SA bus devices	Not used on 4-stage board
	COM	Common for SA BUS power and communication circuits	Negative of the SA BUS circuits
	SA-	Communication for SA BUS devices	Negative of the VDC (typically, a fluctuating 1.5 to 3.5 volts reading to C; at least 0.25 volts lower than +) SA BUS communication circuit to optional economizer board, 4-stage board, fault detection & diagnostics board, netstat and/or MAP-Gateway
	SA+	Communication for SA BUS devices	Positive of the VDC (typically, a fluctuating 1.5 to 3.5 volts reading to C; at least 0.25 volts higher than -) SA BUS communication circuit to optional economizer board, 4-stage board, fault detection & diagnostics board, netstat and/or MAP-Gateway

Four-stage board - temperature sensor connections

Location	Terminal	Description	Function and comments
C	CC3+	#3 refrigerant circuit Condenser Coil temperature sensor input from 10KΩ @ 77°F, Type III negative temperature coefficient thermistor	Input required for heat pump units, not required for A/C units; 3.625 VDC reading CC3+ to CC3- with open circuit. Used in heat pump demand defrost calculation.
	EC3+	#3 refrigerant circuit Evaporator Coil temperature sensor input from 10KΩ @ 77°F, Type III negative temperature coefficient thermistor	Input required for operation; 3.625 VDC reading EC3+ to EC3- with open circuit. Used in suction line temperature safety.
	CC4+	#4 refrigerant circuit Condenser Coil temperature sensor input from 10KΩ @ 77°F, Type III negative temperature coefficient thermistor	Input required for heat pump units, not required for A/C units; 3.625 VDC reading CC4+ to CC4- with open circuit. Used in heat pump demand defrost calculation.
	EC4+	#4 refrigerant circuit Evaporator Coil temperature sensor input from 10KΩ @ 77°F, Type III negative temperature coefficient thermistor	Input required for operation; 3.625 VDC reading EC4+ to EC4- with open circuit. Used in suction line temperature safety.
	AUX-2+	Not Used	Not Used
	AUX-1+	Not Used	Not Used

Four-stage board - quick connect

Location	Terminal	Description	Function and comments
D	COM	Common for Modbus connection to staged heat board	Future
	MB_B	Terminal B for Modbus connection to staged heat board	Future
	MB_A	Terminal A for Modbus connection to staged heat board	Future
	C	Common for HW Valve connection	0-10VDC
	HVV	Analog out for HW Valve	0-10VDC
F	VAV	VAV box Common relay contact	Used to interlock the VAV boxes with RTU morning warm-up
	BOX	VAV box normally open relay contact	Used to interlock the VAV boxes with RTU morning warm-up

Four-stage board - harness connectors

Location	Terminal	Description	Function and comments
E	C	Common for analog outputs	Future
	HGR MOD	0-10VDC analog output for hot gas reheat	Future
	C1 MOD	0-10VDC analog output for C1 modulation	Future
	CF1 MOD	0-10VDC analog output for Condenser Fan 1 modulation	Future
	CF2 MOD	0-10VDC analog output for Condenser Fan 2 modulation	Future

Four-stage board - outputs and cool and heat section connections

Location	Terminal	Description	Function and comments
G	24V FOR OUTPUTS	24 VAC hot for C3, C4, CF2, H3, and HGR	Output relay circuitry is isolated from other 4-stage components and the 24 VAC hot source may be from a second transformer in the unit
H	C3	24 VAC hot output for compressor 3	If demand is present and permissions allow compressor 3 operation
	C4	24 VAC hot output for compressor 4	If demand is present and permissions allow compressor 4 operation
	CF2	24 VAC hot output for the condenser fan contactor coil	Output with either C3 or C4 output.
	H3	24 VAC hot output for heat section stage 3	Not effective for cooling-only units. Output if demand is present and permissions allow heat section operation
	HGR	24 VAC hot output for hot gas reheat	Future

Four-stage board - refrigerant circuit safety switches

Location	Terminal	Description	Function and comments
I	LPS3 (right pin)	24 VAC hot out for refrigerant circuit 3 Low Pressure Switch	Connects through circuit trace to the left HSP3 pin
	LPS3 (left pin)	24 VAC hot return from refrigerant circuit 3 Low Pressure Switch	Input is only considered after 30 seconds of C3 output; afterwards, input must be present to allow C3 output. Three LPS3 trips in a one hour period cause a "Low Pressure Switch 3 Lockout" and C3 output is then prevented until alarm reset.
	HPS3 (right pin)	24 VAC hot out for refrigerant circuit 3 High Pressure Switch	Connects through circuit trace to the R terminal
	HPS3 (left pin)	24 VAC hot return from refrigerant circuit 3 High Pressure Switch	Input is only considered if C3 output is needed; input must be present to allow C3 output. Three HPS3 trips in a two hour period cause a "High Pressure Switch 3 Lockout" and C3 output is then prevented until alarm reset. Connects through circuit trace to the right LPS3 pin.
	LPS4 (right pin)	24 VAC hot out for refrigerant circuit 4 Low Pressure Switch	Connects through circuit trace to the left HSP4 pin
	LPS4 (left pin)	24 VAC hot return from refrigerant circuit 4 Low Pressure Switch	Input is only considered after 30 seconds of C4 output; afterwards, input must be present to allow C4 output. Three LPS4 trips in a one hour period cause a "Low Pressure Switch 4 Lockout" and C4 output is then prevented until alarm reset.
	HPS4 (right pin)	24 VAC hot out for refrigerant circuit 4 High Pressure Switch	Connects through circuit trace to the R terminal
	HPS4 (left pin)	24 VAC hot return from refrigerant circuit 4 High Pressure Switch	Input is only considered if C4 output is needed; input must be present to allow C4 output. Three HPS4 trips in a two hour period cause a "High Pressure Switch 4 Lockout" and C4 output is then prevented until alarm reset. Connects through circuit trace to the right LPS4 pin.

Four-stage board - heat safety circuit

Location	Terminal	Description	Function and comments
J	LIM2	Monitored 24 VAC input through heat section limit switch(es)	If voltage is absent, indicating the heat section is over temperature, the UCB will bring on the indoor blower
	GV2	24 VAC hot input confirming heat section operation	Sourced from gas valve 2 in gas heat units or second stage heat contactor in electric heat units. Input within 5 minutes from initiation of H2 output initiates the Heat On Fan Delay timer, loss of input following the termination of H2 output initiates the Heat On Fan Delay timer, no input within 5 minutes from initiation of H2 output initiates an Ignition Failure alarm, input for longer than 5 minutes without H2 output initiates a Gas Valve Mis-wire alarm
	LIM3	Monitored 24 VAC input through heat section limit switches	If voltage is absent, indicating the heat section is over temperature, the UCB will bring on the indoor blower
	GV3,4	24 VAC hot input confirming heat section operation	

Four-stage board - hot water safety quick connects and thermostat inputs

Location	Terminal	Description	Function and comments
K	FS HWR	Flow switch for Hydronic heat – 24VAC hot output	Flow switch interlock for hot water coil
	FS HW	Flow switch for Hydronic heat – 24VAC hot return	Flow switch interlock for hot water coil
L	Y3	3rd stage cooling request, 24 VAC input switched from R	Visible in the display menu when the #ClgStgs parameter is set for 4, also effective for economizer free cooling supply air temperature reset when the #ClgStgs parameter is set for 4
	Y4	4th stage cooling request, 24 VAC input switched from R	Visible in the display menu when the #ClgStgs parameter is set for 4, also effective for economizer free cooling supply air temperature reset when the #ClgStgs parameter is set for 4
	W3	3rd stage heating request, 24 VAC input switched from R	Not effective for cooling-only units

Table 35: Cable for FC buses and SA buses in order of preference

Bus and cable type	Non-plenum applications		Plenum applications	
	Part number	O.D.	Part number	O.D.
FC Bus: 22 AWG Stranded, 3-Wire Twisted Shielded Cable ¹	Anixter: CBL-22/3-FC-PVC Belden®: B5501FE	0.138 in.	Anixter: CBL-22/3-FC-PLN Belden: B6501FE	0.140 in.
SA Bus (Terminal Block): 22 AWG Stranded, 4-Wire, 2 Twisted-Pair Shielded Cable	Anixter: CBL-22/2P-SA-PVC Belden: B5541FE	0.209 in.	Anixter: CBL-22/2P-SA-PLN Belden: B6541FE	0.206 in.
SA Bus (Modular Jack): 26 AWG Solid 6-Wire, 3 Twisted-Pair Cable ²	—	—	Anixter preassembled: CBL-NETWORK25 CBL-NETWORK50 CBL-NETWORK75 CBL-NETWORK100	0.15 in.
FC Bus: 22 AWG Stranded, 3-Wire Twisted Non-Shielded Cable	Belden: B5501UE	0.135 in.	Belden: B6501UE	0.131 in.
SA Bus (Terminal Block): 22 AWG Stranded, 4-Wire, 2 Twisted-Pair Non-Shielded Cable	Belden: B5541UE	0.206 in.	Belden: B6541UE	0.199 in.

1. We strongly recommend 3-wire (for FC bus) and 4-wire, 2 twisted-pair (for SA bus), 22 AWG stranded, shielded cable. A 22 gauge cable offers the best performance for various baud rates, cable distances, and number of trunk devices primarily due to lower conductor-to-conductor capacitance. Shielded cable offers better overall electrical noise immunity than non-shielded cable. Observe the shield grounding requirements.
2. We recommend 26 AWG solid, 6-wire (3 twisted pairs) cable as the best fit for fabricating modular cables with the modular jack housing assembly. Be sure the cable you use fits the modular jack housing. The preassembled cables that are available from Anixter (Part No. CBL-NETWORKxxx) use 24 gauge wire.

Start-up sheet

START-UP & SERVICE DATA INSTRUCTION**COMMERCIAL PACKAGE UNITS****3.0 To 40.0 TONS****START-UP CHECKLIST**

Date: _____

Job Name: _____

Customer Name: _____

Address: _____

City: _____ State: _____ Zip: _____

Model Number: _____ Serial Number: _____

Qualified Start-up Technician: _____ Signature: _____

HVAC Contractor: _____ Phone: _____

Address: _____

Contractor's E-mail Address: _____

Electrical Contractor: _____ Phone: _____

Distributor Name: _____ Phone: _____

WARRANTY STATEMENT

Johnson Controls/Ducted Systems is confident that this equipment will operate to the owner's satisfaction if the proper procedures are followed and checks are made at initial start-up. This confidence is supported by the 30 day dealer protection coverage portion of our standard warranty policy which states that Johnson Controls/Ducted Systems will cover parts and labor on new equipment start-up failures that are caused by a defect in factory workmanship or material, for a period of 30 days from installation. Refer to the current standard warranty policy and warranty manual for details.

In the event that communication with Johnson Controls/Ducted Systems is required regarding technical and/or warranty concerns, all parties to the discussion should have a copy of the equipment start-up sheet for reference. A copy of the original start-up sheet should be filed with the Technical Services Department.

The packaged unit is available in constant or variable air volume versions with a large variety of custom options and accessories available. Therefore, some variation in the startup procedure will exist depending upon the products capacity, control system, options and accessories installed.

This start-up sheet covers all startup check points common to all package equipment. In addition it covers essential startup check points for a number of common installation options. Depending upon the particular unit being started not all sections of this startup sheet will apply. Complete those sections applicable and use the notes section to record any additional information pertinent to your particular installation.

Warranty claims are to be made through the distributor from whom the equipment was purchased.

EQUIPMENT STARTUP

Use the local LCD or Mobile Access Portal (MAP) Gateway to complete the start-up.

A copy of the completed start-up sheet should be kept on file by the distributor providing the equipment and a copy sent to:

Johnson Controls/Ducted Systems
 Technical Services Department
 5005 York Drive
 Norman, OK 73069

1034349-UCL-F-0318

SAFETY WARNINGS

The inspections and recording of data outlined in this procedure are required for start-up of Johnson Controls/Ducted Systems' packaged products. Industry recognized safety standards and practices must be observed at all times. General industry knowledge and experience are required to assure technician safety. It is the responsibility of the technician to assess all potential dangers and take all steps warranted to perform the work in a safe manner. By addressing those potential dangers, prior to beginning any work, the technician can perform the work in a safe manner with minimal risk of injury.

 WARNING
Lethal voltages are present during some start-up checks. Extreme caution must be used at all times.

 WARNING
Moving parts may be exposed during some startup checks. Extreme caution must be used at all times.

NOTE: Read and review this entire document before beginning any of the startup procedures.

DESIGN APPLICATION INFORMATION

This information will be available from the specifying engineer who selected the equipment. If the system is a VAV system the CFM will be the airflow when the remote VAV boxes are in the

full open position and the frequency drive is operating at 60 HZ. **Do not proceed with the equipment start-up without the design CFM information.**

Design Supply Air CFM: _____ Design Return Air CFM: _____

Design Outdoor Air CFM At Minimum Position: _____

Total External Static Pressure: _____

Supply Static Pressure: _____

Return Static Pressure: _____

Design Building Static Pressure: _____

Outside Air Dilution: Economizer Position Percentage: _____ CFM: _____

Supply Gas Pressure After Regulator W/o Heat Active _____ Inches _____

ADDITIONAL APPLICATION NOTES FROM SPECIFYING ENGINEER:

1034349-UCL-F-0318

REFERENCE

General Inspection	Completed	See Notes
Unit inspected for shipping, storage, or rigging damage	<input type="checkbox"/>	<input type="checkbox"/>
Unit installed with proper clearances	<input type="checkbox"/>	<input type="checkbox"/>
Unit installed within slope limitations	<input type="checkbox"/>	<input type="checkbox"/>
Refrigeration system checked for gross leaks (presence of oil)	<input type="checkbox"/>	<input type="checkbox"/>
Terminal screws and wiring connections checked for tightness	<input type="checkbox"/>	<input type="checkbox"/>
Filters installed correctly and clean	<input type="checkbox"/>	<input type="checkbox"/>
Economizer hoods installed in operating position	<input type="checkbox"/>	<input type="checkbox"/>
Condensate drain trapped properly, refer to Installation Manual	<input type="checkbox"/>	<input type="checkbox"/>
Economizer damper linkage tight	<input type="checkbox"/>	<input type="checkbox"/>
Gas Heat vent hood installed	<input type="checkbox"/>	<input type="checkbox"/>
All field wiring (power and control) complete	<input type="checkbox"/>	<input type="checkbox"/>

Air Moving Inspection	Completed	See Notes
Alignment of drive components	<input type="checkbox"/>	<input type="checkbox"/>
Belt tension adjusted properly	<input type="checkbox"/>	<input type="checkbox"/>
Blower pulleys tight on shaft, bearing set screws tight, wheel tight to shaft	<input type="checkbox"/>	<input type="checkbox"/>
Pressure switch or transducer tubing installed properly	<input type="checkbox"/>	<input type="checkbox"/>

Exhaust Inspection Powered <input type="checkbox"/> Barometric Relief <input type="checkbox"/>	Completed	See Notes
Check hub for tightness	<input type="checkbox"/>	<input type="checkbox"/>
Check fan blade for clearance	<input type="checkbox"/>	<input type="checkbox"/>
Check for proper rotation	<input type="checkbox"/>	<input type="checkbox"/>
Check for proper mounting (screen faces towards unit)	<input type="checkbox"/>	<input type="checkbox"/>
Prove operation by increasing minimum setting on economizer	<input type="checkbox"/>	<input type="checkbox"/>

Economizer Inspection Standard <input type="checkbox"/> BAS <input type="checkbox"/>	Completed	See Notes
CO ₂ sensor installed Yes <input type="checkbox"/> No <input type="checkbox"/>	<input type="checkbox"/>	<input type="checkbox"/>
Check economizer setting (Reference Smart Equipment™ Control Board LCD menu location)	<input type="checkbox"/>	<input type="checkbox"/>
Prove economizer open/close through Smart Equipment™ Board Setting	<input type="checkbox"/>	<input type="checkbox"/>

Reheat Mode Normal <input type="checkbox"/> or Alternate <input type="checkbox"/> Not Applicable <input type="checkbox"/>
Humidity Sensor (2SH0401) _____

Ducted Systems

Operating Measurements - Air Flow

Fan operates with proper rotation (All VFD equipped units with the optional Manual Bypass must be phased for correct blower rotation with the Bypass switch set in the LINE position) ID Fans Exh. Fans Cond. Fans

Pressure drop across dry evaporator coil (At maximum design CFM) ¹	IWC
External Static Pressure	IWC
Return Static Pressure	IWC
Supply Static Pressure	IWC
Supply Air CFM Using Dry Coil Chart	CFM
Final Adjusted Supply Air CFM ²	CFM

1. Consult the proper airflow to pressure drop table to obtain the actual airflow at the measured pressure differential.
2. Was a motor pulley adjustment or change required to obtain the correct airflow?
 Was it necessary to increase or decrease the airflow to meet the design conditions?
 If the motor pulley size was changed, measure the outside diameters of the motor and blower pulleys and record those diameters here;

Blower Motor HP _____ FLA _____ RPM _____

Pulley Pitch Diameter _____ Turns Out _____ Final Turns Out _____

Blower Pulley Pitch Diameter _____ Fixed Sheave _____

ELECTRICAL DATA

T1 - T2 _____ Volts T2 - T3 _____ Volts

Control Voltage _____ Volts T1 - T3 _____ Volts

Device	Nameplate	Measured List All Three Amperages
Supply Fan Motor ^{1, 2}	AMPS	AMPS
Exhaust Motor (Dampers 100%)	AMPS	AMPS
Condenser Fan #1	AMPS	AMPS
Condenser Fan #2 (if equipped)	AMPS	AMPS
Condenser Fan #3 (if equipped)	AMPS	AMPS
Condenser Fan #4 (if equipped)	AMPS	AMPS
Compressor #1	AMPS	AMPS
Compressor #2 (if equipped)	AMPS	AMPS
Compressor #3 (if equipped)	AMPS	AMPS
Compressor #4 (if equipped)	AMPS	AMPS

1. VAV units with heat section - simulate heat call to drive VAV boxes and VFD/IGV to maximum design airflow position.
2. VAV units without heat section - VAV boxes must be set to maximum design airflow position.

1034349-UCL-F-0318

OPERATING MEASUREMENTS - COOLING

Stage	Discharge Pressure	Discharge Temp.	Liquid Line Temp. ¹	Subcooling ²	Suction Pressure	Suction Temp.	Superheat
First	#	°	°	°	#	°	°
Second (if equipped)	#	°	°	°	#	°	°
Third (if equipped)	#	°	°	°	#	°	°
Fourth (if equipped)	#	°	°	°	#	°	°
Reheat 1st Stage	#	°	°	°	#	°	°

- Liquid temperature should be taken before filter/drier.
- Subtract 10 psi from discharge pressure for estimated liquid line pressure

Outside air temperature	_____	°F db	_____	°F wb	_____	%RH
Return Air Temperature	_____	°F db	_____	°F wb	_____	%RH
Mixed Air Temperature	_____	°F db	_____	°F wb	_____	%RH
Supply Air Temperature	_____	°F db	_____	°F wb	_____	%RH

REFRIGERANT SAFETIES

Action	Completed	See Notes
Prove Compressor Rotation (3 phase only) by gauge pressure	<input type="checkbox"/>	<input type="checkbox"/>
Prove High Pressure Safety, All Systems	<input type="checkbox"/>	<input type="checkbox"/>
Prove Low Pressure Safety, All Systems	<input type="checkbox"/>	<input type="checkbox"/>

OPERATING MEASUREMENTS - GAS HEATING

Fuel Type: Natural Gas LP Gas

Action	Completed	See Notes
Check for gas leaks	<input type="checkbox"/>	<input type="checkbox"/>
Prove Ventor Motor Operation	<input type="checkbox"/>	<input type="checkbox"/>
Prove Primary Safety Operation	<input type="checkbox"/>	<input type="checkbox"/>
Prove Auxiliary Safety Operation	<input type="checkbox"/>	<input type="checkbox"/>
Prove Rollout Switch Operation	<input type="checkbox"/>	<input type="checkbox"/>
Prove Smoke Detector Operation	<input type="checkbox"/>	<input type="checkbox"/>
Manifold Pressure	Stage 1	IWC <input type="checkbox"/>
	Stage 2 (If Equipped)	IWC <input type="checkbox"/>
	Stage 3 (If Equipped)	IWC <input type="checkbox"/>
Supply gas pressure at full fire	IWC	<input type="checkbox"/>
Check temperature rise ¹	<input type="checkbox"/> measured at full fire	°F <input type="checkbox"/>

- $\frac{\text{Input X Eff. (BTU output)}}{1.08 \times \text{Temp. Rise}}$

Ducted Systems

OPERATIONAL MEASUREMENTS - STAGING CONTROLS

Verify Proper Operation of Heating/Cooling Staging Controls	
Create a cooling demand at the Thermostat, BAS System or Smart Equipment™ Verify that cooling/economizer stages are energized.	<input type="checkbox"/>
Create a heating demand at the Thermostat, BAS System or Smart Equipment™ Verify that heating stages are energized.	<input type="checkbox"/>
Verify Proper Operation of the Variable Frequency Drive (If Required)	
Verify that motor speed modulates with duct pressure change.	<input type="checkbox"/>

FINAL - INSPECTION

Verify that all operational control set points have been set to desired value Scroll through all setpoints and change as may be necessary to suit the occupant requirements.	<input type="checkbox"/>
Verify that all option parameters are correct Scroll through all option parameters and ensure that all installed options are enabled in the software and all others are disabled in the software. (Factory software settings should match the installed options)	<input type="checkbox"/>
Verify that all access panels have been closed and secured	<input type="checkbox"/>
Save a backup file from the unit control board onto a USB flash drive.	<input type="checkbox"/>

OBSERVED PRODUCT DEFICIENCIES & CONCERNS:
